

# Optimisation of IrDA IrLAP Link Access Protocol

V. Vitsas and A.C. Boucouvalas  
Multimedia Communications Group  
School of Design, Engineering and Computing  
Bournemouth University  
Talbot Campus, Fern Barrow,  
Poole BH12 5BB, UK  
email: {vvitsas, tboucouv}@bournemouth.ac.uk

## Abstract

The widespread installation of millions of IrDA infrared ports in mobile devices for wireless communication applications necessitates for throughput performance optimisation of the IR links at the IrLAP link layer. Link layer throughput optimisation is important for any line BER of the IR links. The paper provides a mathematical model based on which we derive a simple equation linking IrLAP throughput with physical and link layer parameters. Simple equations for optimum values of window and frame size lengths for maximum link layer throughput as a function of BER are derived. A study of the importance of parameters such as link minimum turn around time and  $t_{Fout}$  timer is presented. Finally a protocol improvement that utilises special Supervisory frames (S-frames) to pass transmission control is proposed to deal with delays introduced by F-timer expiration. Results indicate that employing the special S-frame highly improves throughput performance when optimum window and frame size values are implemented.

Index terms: Wireless Communications, Optical Wireless, IrDA, IR links.

## I. Introduction

Recent growth on laptop computers and on portable devices, such as personal digital assistants (PDAs) and digital cameras, leads to an increasing demand for information transfer from or between portable devices [1]. Digital representation of information is expanding to new devices such as video and photo cameras. New devices have “computer like” capabilities for storing and retrieving information such as mobile phones and portable information gathering appliances. Computer manufacturers have adopted the Infrared Data Association (IrDA) standard [2] and almost every portable computer and all Windows CE devices on market today contain an infrared port according to standards developed by IrDA. Laptop computers, personal digital assistants (PDAs), digital cameras, mobile phones and printers are examples of devices with IrDA links. More than 40 million devices are shipped each year with IrDA ports [3] capable of using the unregulated infrared spectrum for their cable-less communication needs.

IrDA developed a standard for low-cost, indoor, short range, half duplex, point to point links [4]. Ir-PHY, the IrDA physical layer specification [5] supports optical links from zero to at least 1 meter, an angle of  $\pm 15$  degrees at a Bit Error Rate (BER) of less than  $10^{-8}$ . Ir-PHY ver 1.0 Serial Infrared (SIR) specification [6] supported data rates up to 115.2 Kbit/s using standard serial hardware, Ir-PHY ver 1.1 Fast Infrared (FIR) [7] extended data speed to 4Mbit/s and finally Ir-PHY ver 1.3 Very Fast Infrared (VFIR) [8] specification added the 16Mbit/s link rate. The IrDA hardware is controlled by a link layer protocol, the IrDA Link Access Protocol (IrLAP) [9]. IrLAP is based on the widely used HDLC protocol operating in Normal Response Mode (NRM). The performance of IrDA optical wireless links may be measured by the throughput which can be drawn at the IrLAP layer.

In this paper, we concentrate on the performance evaluation of the IrLAP protocol and on deriving optimum values for link layer parameters for maximising throughput. In the literature, a mathematical model for the IrLAP throughput using the concept of a frame's ‘virtual transmission time’ is presented in [11][12] based on the HDLC analysis model presented in [13]. However, this model does not lead to a simple formula for the IrLAP throughput. In this work, a new mathematical model based on the concept of ‘window transmission time’ is developed. By taking advantage of IrLAP half duplex operation, this model leads to a simple closed form formula for IrLAP throughput. The formula relates throughput with physical layer parameters, such as link

BER, link data rate and minimum turn around time, and with link layer parameters such as frame size, window size and frame overhead. As this equation gives us an intuitive understanding of the performance of IrDA links, it would be very valuable for designers and implementers of such links. By differentiating we derive the optimum values for window size and packet size that maximise throughput. Formulas for all IrLAP time consuming tasks are also presented, allowing evaluation of link parameter values to throughput performance. IrLAP performance is examined for various link parameters, such as BER, data rate, window size etc. and compared with optimum performance achieved by using optimum window size and packet size values. Optimum window and frame size values can be easily implemented and results in significant throughput increase, especially for links experiencing high BERs. However, implementing optimum frame size values on retransmissions requires buffer reorganisation at low level.

The paper is outlined as follows. Section II briefly describes the IrDA protocol stack and section III presents the IrLAP layer procedures and parameter definitions. The information transfer model employed for IrLAP throughput evaluation is discussed in section IV and section V presents a mathematical model based on the concept of 'window transmission time' employed for evaluation of IrLAP throughput and of other IrLAP time consuming tasks. The IrLAP throughput performance is analysed in section VI in relation to physical and link layer parameters and optimum window and frame size values for maximum throughput are derived in section VII. This section also validates the mathematical analysis for maximum throughput performance by comparing results obtained by equations for optimum window and frame size values with results obtained by employing numerical methods for maximum IrLAP throughput. Throughput performance achieved by employing optimum values for window and/or frame size is presented in section VIII and concluding remarks are given in section IX.

## **II. The IrDA protocol stack**

The IrDA architecture is presented in Fig. 1. SIR presents hardware specifications for 2.4 Kbit/s to 115.2 Kbit/s using conventional serial UART chips. It employs RZI modulation scheme and a '0' is represented by a light pulse. The optical pulse duration is nominally 3/16 of a bit duration and the maximum receiver latency allowance is 10ms. FIR introduced 0.576 Mbit/s and 1.152 Mbit/s data rates employing RZI modulation and 4Mbit/s data rate employing 4PPM modulation scheme. IrPHY specifies a link distance of at least 1m and an off axis angle of  $\pm 15$  degrees but, due to

component tolerance, adequate link operation at angles of 30 degrees is achieved [4]. VFIR added 16Mbit/s data rate by using a newly developed HHH(1,13) code and reduced the allowable receiver latency to 0.1ms. The Link Management Protocol consists of the Link Management Multiplexer (LM-MUX) and the Link Management Information Access Service (LM-IAS). LM-MUX is a connection oriented multiplexer that allows multiple applications in an IrDA device to communicate over a single IrLAP connection and LM-IAS facilitates discovery of services available by the communicating device. An IrDA service claims an LM-MUX port and advertise itself to the communicating device by placing its service information and necessary parameters in a lookup table. Implementation of IrPHY, IrLAP and IrLMP is required from all IrDA-compliant devices. TinyTP is a useful light-weight transport protocol for segmentation and reassembly operations and for application level flow control. IrCOMM is the cable replacement of the IrDA stack. IrCOMM is a serial and parallel port emulation protocol, enabling all applications designed to operate over serial or parallel ports to operate unchanged over the infrared medium. IrCOMM allows both DTE-DTE (null modem) and DTE-DCE connections. IrLAN allows station LAN access over an IrDA link and IrOBEX is the IrDA HTTP protocol, facilitating simple data object (business card, phone list) exchange. IrTRAN-P allows the exchange of images between digital cameras, photo printers and PCs while IrJetSend allows IrDA binding to Hewlett-Packard JetSend protocol [3][4].

### **III. The IrLAP layer**

IrLAP is the IrDA data link layer. It is designed based on the pre-existing HDLC and SDLC protocols [9]. IrLAP stations operate in two modes, in the Normal Disconnect Mode (NDM) during the contention period and in the Normal Response Mode (NRM) during the connection period. In the contention period, a station advertises its existence in the neighbour stations along with the link parameters it supports and wishes to employ during link establishment. One of the participating stations becomes the primary station. Any station may claim to become the primary station but, at the end of the contention period, only one station is assigned the primary role and all other stations are assigned the secondary role. All data traffic during the connection period are sent to or from the primary station. A secondary station wishing to communicate to another secondary station, it does so through the primary station. NDM negotiation occurs at 9.6 Kbit/s, which means that an IrDA

compliant station must support this data rate. The parameters negotiated and agreed in NDM are given below:

- a) *Data rate*. This parameter specifies the station's transmission rate. Both stations must use the same data rate.
- b) *Maximum turn around time*. This parameter specifies the maximum time interval a station can hold transmission control. It is negotiated and agreed independently for each station. For data rates less than 115.2 Kbit/s maximum turn around time must be 500ms. A smaller value may be agreed between the two stations for 115.2 Kbit/s or higher speeds.
- c) *Data size*. This is the maximum length in bytes allowed for the data field in any received Information frame (I-frame). This parameter is also negotiated independently for each station and has an upper limit of 2,048 bytes (16Kbits).
- d) *Window size*. This is the maximum number of unacknowledged frames a station can receive before it has to acknowledge the number of frames received correctly. An acknowledgement may be requested by the sending station before the window size is reached. This parameter is also negotiated independently for each station and has an upper limit of 7 for speeds up to 4Mbit/s and 127 for 4Mbit/s and 16Mbit/s [9][10].
- e) *Minimum turn around time*. This is the time required by the station's receiver circuit to recover after the end of a transmission initiated from the same station (turn around latency). Each station must wait a *minimum turn around time* delay when moving from receive mode to transmit mode to ensure that the receiver circuit of the station that was transmitting is given enough time to recover. This is the time required to change link direction and is also negotiated independently for each station.
- f) *Link disconnect/threshold time*. The station disconnects the link if it does not receive a valid frame during this time period.
- g) *Additional BOFs*. This is the number of additional flags required in the beginning of any received frame. The time delay provided by the additional flags in the beginning of each frame is essential for devices with long interrupt latency.

The IrDA frame structure is shown in Fig. 2. IrPHY frame consists of START flag, the IrLAP frame, the Frame Check Sequence (FCS) to protect frame data and the STOP flag. FCS contains a

16-bit CRC for data rates up to 4 Mbit/s and a 32-bit CRC for 4Mbit/s and higher rates. IrLAP employs the following frame types:

- a) Unnumbered frames (U-frames) are used for link management. U-frame functions include discovering and initialising secondary stations, reporting procedural errors not recoverable by retransmissions etc.
- b) Information frames (I-frames) carry information data across the link during the connection period. I-frame control field contains send and receive frame counts to ensure in order frame reception.
- c) Supervisory frames (S-frames) assist in information data transfer although S-frames never carry information data themselves. They are used to acknowledge correctly received frames, request an acknowledgement from the communicating station, convey station conditions etc.

The control field contains an identifier, which determines the frame type. Depending of frame type, the control field may contain a send sequence number,  $N_s$ , used to number the sent frames. It may also contain a receive sequence number,  $N_r$ , used to indicate the sequence number of the next frame expected. SIR and FIR specifications employ an 8-bit long control field.  $N_s$  and  $N_r$  occupy 3 bits each in the control field, thus  $N_s$  and  $N_r$  cycle through values from 0 to 7 and maximum window size is 7. VFIR specification extended the control field to 16 bit for 4 Mbit/s and 16 Mbit/s data rate IrDA links. In this case,  $N_s$  and  $N_r$  occupy 7 bits each, cycling through values 0 to 127 and a maximum window size of 127 is allowed.

Within the control field the P/F bit implements token passing between stations. When it is set by the primary station, it is the poll (P) bit. When it is set by the secondary station, it is the final (F) bit. Primary uses the P bit to reverse link direction and solicit a response from the secondary. The secondary responds by transmitting one or more frames and by setting the F bit of the last frame it transmits, thus reversing the link direction and returning transmission control to the primary. IrLAP primary and secondary stations also employ a P-timer. P-timer is assigned with the maximum turn around time agreed between stations during link establishment and represents the maximum time a station can hold transmission control. Each station starts the P-timer upon reception of a frame with the P/F bit set and stops the P-timer when it transmits a frame with a P/F bit set. If P-timer expires, meaning that the station holds transmission control longer than allowed, the station immediately sends a Receive Ready (RR) S-frame with the P/F bit set to pass transmission control. The primary

station also employs an F-timer to limit the time a secondary station can hold transmission control. The primary starts the F-timer upon transmission of a frame with the P-bit set and stops F-timer upon reception of a frame with the F-bit set. F-timer expiration means that the secondary failed to return transmission control within the agreed time period. Since the secondary's P-timer operation guarantees that this never happens, F-timer expiration can only be explained by assuming that either the frame contained the P bit or the frame contained the F bit is lost. The primary resolves this situation by transmitting a RR frame with the P-bit set when F-timer expires.

#### IV. IrLAP functional model description

In the current work, transmission of large amount of information from the primary to the secondary station is considered as IrDA links are usually employed for information transfer from one device to another. Typical examples are downloading pictures form a digital photo camera to a laptop computer for processing, downloading data from a portable information gathering appliance to a host computer, transferring a phone list from a mobile phone to a computer or the another mobile and printing a file from a laptop to a (usually inkjet) printer. The saturation case is assumed, where the primary station always has information data ready for transmission.

The parameters used in the current model are shown in Table 1. In the negotiation stage, the primary station determines the window size  $N$  it will employ.  $N$  represents the maximum number of I-frames the primary can transmit before soliciting an acknowledgement. Maximum window size parameter  $W_{max}$  is negotiated and agreed between the two stations during link establishment. However, the maximum time a station can hold transmission control,  $T_{max}$ , must always be obeyed and, according to IrLAP specification [9],  $T_{max}$ , combined with frame size and link rate may limit the window size applied. In other words, if time needed for transmitting  $W_{max}$  frames carrying 'frame size' information bytes at the link data rate exceeds  $T_{max}$ , then a smaller window size must be employed. Thus,  $N$  is giver by

$$N = \min \left\{ W_{max}, \text{floor} \left( \frac{T_{max}}{t_l} \right) \right\} \quad (1)$$

where  $\min$  is 'the lesser of' and  $\text{floor}$  is 'the largest integer not exceeding'. In current work  $T_{max}$  is always fixed to 500 ms.

The information transfer procedure used in current model is presented in Fig 3. Each node holds three variables,  $V_s$  for counting frames transmitted,  $V_r$  for counting frames received and  $w$

indicating the number of I-frames the station can transmit before reversing link direction. The primary also employs an F-timer for limiting the secondary's transmission period. When the primary station sends a data frame, the  $N_s$  sub-field of frame's control field is assigned the current  $V_s$  value and  $V_s$  is increased by 1 (modulo 8 or 128 depending of control field size employed). The primary also makes a frame's buffer copy for possible retransmissions. Since the primary always has information ready for transmission, it immediately checks the  $w$  value. If  $w$  is not equal to 1, primary reduces  $w$  by 1, transmits the I-frame with the P-bit not set and the actions previously described are repeated. When  $w$  reaches 1, indicating that the next I-frame should be the last frame in the window transmission, the primary sets the P-bit to poll the secondary and transmits the I-frame. The primary also assigns  $N$  to  $w$  for the next  $N$  window frame transmission and starts the F-timer.

When the secondary station receives an I-frame, it compares the received frame sequence  $N_s$  value with station's expected  $V_r$  value. If  $N_s$  equals  $V_r$  (the received frame is in sequence),  $V_r$  is increased by 1 (modulo 8 or 128) and information data is extracted and passed to the upper layer. If the received frame is not in sequence (one of the previous I-frames in current window transmission was lost due to a CRC detected error), the frame is discarded and  $V_r$  remains unchanged. The secondary also checks the P bit. If the P bit is set and as the current model assumes that the secondary station never has information for transmission, it awaits a *minimum turn around time*  $t_{ta}$  to allow for the receiver's hardware recovery latency and transmits an S-frame with the F-bit set. The S-frame's  $N_r$  field contains  $V_r$ , a value informing the primary of the number of I-frames received correctly and in sequence in the previous window transmission. When the primary receives the S-frame, it resumes I-frame transmission as transmission control was returned to the primary by means of the F-bit. The primary first compares the received S-frame's  $N_r$  with current  $V_s$  value. If  $N_r$  equals to  $V_s$  (all frames in the previous window transmission were received correctly by the secondary), the primary transmits I-frames containing new information data to the secondary. If  $N_r$  is not equal to  $V_s$ , one or more I-frames in the previous window transmission are lost. The primary retransmits buffered I-frames starting from the indicated  $N_r$  position before new data can be transmitted.

If the last I-frame that contains the P-bit is lost, the secondary station fails to respond as it does not realise that it has transmission control. The situation is resolved by primary's F-timer expiration. The primary realises that secondary failed to respond during the agreed time period and transmits

an S-frame forcing the secondary to respond. In the current model, S-frames are considered small enough to be always received error free.

The saturation case model considered in current work can be summarised as follows. The transmitting station always has information ready for transmission. As a result, it transmits a window of  $N$  consecutive I-frames and reverses the link direction by setting the P bit in the last I-frame. The receiver awaits a minimum turn around time and responds with a RR S-frame indicating the next frame expected. RR frames always have the F bit set. The transmitter determines the number of frames correctly received before any error(s) occurred and repeats the erred frame and the frames following it, in the next window, followed by new frames to form a complete  $N$  frame transmission. If the last frame in a window transmission is lost, the receiver fails to respond as the P bit is lost. When F-timer expires, the primary station sends a RR S-frame with the P bit set forcing the secondary station to acknowledge correctly received frames.

#### **V. IrLAP mathematical model**

The values for  $t_s$ ,  $t_I$ ,  $t_{ack}$ ,  $p$  and  $D_b$  are given by (Fig. 4):

$$t_s = \frac{l'}{C} \quad (2)$$

$$t_I = \frac{l+l'}{C} \quad (3)$$

$$t_{ack} = 2t_{ta} + t_s \quad (4)$$

$$p = 1 - (1 - p_b)^{l+l'} \quad (5)$$

$$D_b = lD_f \quad (6)$$

This model uses the concept of “window transmission time” (WTT) to represent the time needed for a complete window frame transmission and for acknowledgements and delays concerning this transmission. WTT accounts for the time taken from the start of the first frame in a window transmission to the start of the first frame in the next window transmission. WTT incorporates time needed for I-frame transmissions, for acknowledgements, for reversing link direction and time wasted in possible timer time out delays.

As shown in Fig. 4, the key issue that determines WTT is the reception of the last frame in window, the frame that contains the P bit. If this frame is correctly received and regardless of the existence of previous errors, Fig. 4(a),(b),(c), WTT  $t_w$  is given by

$$t_w = Nt_I + t_{ack} \quad (7)$$

If the I-frame containing the P bit is lost, an additional delay for F-timer expiration and an S-frame transmission  $t_s$  is introduced. WTT is independent of possible additional errors. This situation is shown in Fig. 4(d),(e) and WTT is given by

$$t_w = Nt_I + t_{Fout} + t_s + t_{ack} \quad (8)$$

As an I-frame is incorrectly received with probability  $p$ , the average WTT is given by

$$t_w = Nt_I + p(t_{Fout} + t_s) + t_{ack} \quad (9)$$

Considering that all I-frames, that follow an I-frame incorrectly received in an  $N$  window frame transmission, are considered out of sequence and discarded by the receiver, the probability  $p_c(w)$  that exactly  $w$  frames at the beginning of a window transmission are correctly received followed by an incorrectly received frame is

$$p_c(w) = (1-p)^w p, \quad w=1,2,\dots,N-1 \quad (10)$$

The probability that all I-frames in a window transmission are correctly received is

$$p_c(N) = (1-p)^N \quad (11)$$

The expected number of correctly received frames,  $p_{all}$ , at the beginning of an  $N$  I-frame window transmission is

$$p_{all} = \sum_{w=1}^N w p_c(w), w=1,2,\dots,N \quad (12)$$

Frame throughput  $D_f$  can now be found by dividing the expected number of frames,  $p_{all}$ , correctly received in a window transmission by the average WTT required for that transmission

$$D_f = \frac{\sum_{w=1}^N w p_c(w)}{Nt_I + p(t_{Fout} + t_s) + t_{ack}} \quad (13)$$

After some algebra, (13) reduces to

$$D_f = \frac{1-p}{p} \frac{(1-(1-p)^N)}{Nt_I + p(t_{Fout} + t_s) + t_{ack}} \quad (14)$$

and by combining (6) with (14), link throughput is given by

$$D_b = l \frac{1-p}{p} \frac{(1-(1-p)^N)}{Nt_I + p(t_{Fout} + t_s) + t_{ack}} \quad (15)$$

An intuitive explanation of (14) is as follows. Term  $1-p/p$  represents the expected number of frames correctly received before a frame error occurs. It counts for the frames from the first frame in a window transmission that follows a window containing an error to the first frame error. Term  $(1-(1-p)^N)$  is the probability that there is at least an error in a window transmission and term  $Nt_I + p(t_{Fout} + t_s) + t_{ack}$  stands for average WTT.

A mathematical model for the IrLAP saturation throughput is presented in [11]. An extensive discussion on IrLAP mathematical models can also be found at [15]. Current analysis allows evaluation of all component tasks affecting the IrLAP throughput. Such an evaluation reveals the main factors resulting in throughput degradation for IrLAP operation under no ideal conditions. Equation (15) can be rewritten as

$$D_b = l \frac{1-p}{p} \frac{(1-(1-p)^N)}{N \frac{l+l'}{C} + p(t_{Fout} + t_s) + t_{ack}} \quad (16)$$

Time portion attributed to acknowledgements  $T_{ack}$  is given by

$$T_{ack} = \frac{t_{ack}}{N \frac{l+l'}{C} + p(t_{Fout} + t_s) + t_{ack}} \quad (17)$$

Time portion used on P-bit loss and F-timer expiration  $T_{Fout}$  is given by

$$T_{Fout} = \frac{p(t_{Fout} + t_s)}{N \frac{l+l'}{C} + p(t_{Fout} + t_s) + t_{ack}} \quad (18)$$

Time portion taken on transmitting frame overheads  $l'$  is given by

$$T_{l'} = \frac{\frac{Nl'}{C}}{N \frac{l+l'}{C} + p(t_{Fout} + t_s) + t_{ack}} \quad (19)$$

As the expected number of error frames in a window transmission is  $Np$ , time portion spent on retransmission of error frames  $T_{error}$  is

$$T_{error} = \frac{\frac{Npl}{C}}{N \frac{l+l'}{C} + p(t_{Fout} + t_s) + t_{ack}} \quad (20)$$

The expected number of correctly transmitted frames following an error frame in a window transmission can be found if from the total number of frames in a window  $N$ , we subtract the error frames  $Np$  and the correct in sequence frames  $\frac{1-p}{p}(1-(1-p)^N)$ . Thus the time portion spent on retransmitting correctly received out of sequence frames is given by

$$T_{corr} = \frac{\left( N - \frac{1-p}{p}(1-(1-p)^N) - Np \right) \frac{l}{C}}{N \frac{l+l'}{C} + p(t_{Fout} + t_s) + t_{ack}} \quad (21)$$

## VI. Throughput analysis.

Equation (14) allows an intuitive understanding of the IrLAP performance. Three factors contribute to average WTT given in (9). Factor  $Nt_l$  represents for user data transmission, factor  $p(t_{Fout}+t_s)$  represents for lost P/F bit overhead and  $t_{ack}$  the delays introduced by reversing link direction. It is clear that for very low BERs, factor  $p(t_{Fout}+t_s)$  introduces negligible overhead as the P/F bit is seldom lost. Table 2 shows  $Nt_l$  and  $t_{ack}$  factors for IrPHY data rate evolution over the years. It presents the speed(s) introduced by every new specification, the year introduced, the specification's maximum window size, the maximum window size that can be enforced for 16Kbit frames within  $T_{max}$  (effective  $N$ ), specification's  $t_{ta}$  and the two factors contributing to WTT. Table 2 reveals that the FIR specification introduced much higher speeds (up to 4Mbit/s) without the expected change in the maximum  $t_{ta}$  value allowed for FIR IrDA ports. As a result, the time for user data transmission dropped from 427.9 ms to 28.8 ms while the time spent on reversing the link direction twice was constant at 20 ms since  $t_{ta}$  was not changed. As a result, 4Mbit/s IrDA links employing minimum turnaround time  $t_{ta}=10$ ms utilise 20ms for acknowledgements for every 28.8ms of data transmission! Fig. 5 plots throughput efficiency versus BER for SIR and FIR link rates with  $t_{ta}=10$ ms,  $W_{max}=7$ ,  $l=16$ Kbits and  $t_{Fout} = t_{lmax} + 2t_{ta}$ . Throughput efficiency decreases with data rate increase since link turn around frequency is increased. As a result a maximum throughput efficiency of 0.59 can be achieved for 4 Mbit/s links.

VFIR specification, along with introducing the higher 16Mbit/s rate, addressed the problem by reducing  $t_{ta}$  to 0.1 ms and by optionally increasing window size to 127 frames for 16Mbit/s links. The standard also introduced an optional window size increase to 127 frames for the existing 4Mbit/s links in an effort to solve the existing problem. Fig. 5 also plots throughput efficiency versus link BER for 4 Mbit/s links with  $t_{ta}=10\text{ms}$ ,  $l=16\text{Kbits}$  and  $W_{max}=127$  frames. Throughput efficiency significantly increases with the 127 window size employment and reaches 0.96. Fig. 6 plots throughput efficiency versus link BER. It examines the effect of reducing  $t_{ta}$  and/or increasing window size in throughput efficiency for the 16 Mbit/s link. Throughput efficiency for  $t_{ta}=10\text{ms}$  and  $W_{max}=7$  shows that the increased turnaround frequency results in poor performance. Reducing acknowledgement time portion by only increasing window size ( $t_{ta}=10\text{ms}$  and  $W_{max}=127$ ) results in a significant increase but yet a questionable performance. By reducing only  $t_{ta}$  ( $t_{ta}=0.1\text{ms}$  and  $W_{max}=7$ ) an excellent performance is observed. Taking further advantage of the optional window size increase ( $t_{ta}=0.1$  ms and  $W_{max}=127$ ) results a slightly better performance for low BER but renders the link vulnerable to BER increase as it requires a link BER of  $10^{-8}$  to achieve an excellent performance as opposed to a  $10^{-7}$  BER requirement for  $W_{max}=7$ . As a conclusion,  $t_{ta}$  adjustment is a necessity while the effectiveness of window size increase is debatable.

Fig. 7 plots throughput efficiency versus window size for different link BERs for 16Mbit/s links. Window size increase results in slight throughput increase for low BERs and significant decrease for high BERs. Fig. 8 plots throughput efficiency versus window size for 4Mbit/s links with  $t_{ta}=10\text{ms}$ . A much different behaviour is observed due to the large link turnaround time value as related to link speed. A significant throughput increase with window size increase for low BER is observed as the link turnaround frequency is decreased. This also applies for high BER ( $10^{-6}$ ) but when window size becomes very large, a throughput decrease is observed caused by increased number of transmitted frames following an error frame in a window transmission.

Fig. 9 shows time allocation for different tasks for the 16Mbit/s link with  $W_{max}=127$  and  $t_{ta}=0.1$  ms. It reveals that for large window size values ( $W_{max}=127$ ), the key factor that reduces throughput for a wide range of BER (from  $10^{-8}$  to  $10^{-4}$ ) is the retransmission of correctly received out of sequence frames. This is a limitation of the IrDA IrLAP protocol when non-optimum window size is used, especially for high BER. Fig. 10 plots throughput efficiency versus frame size for 16Mbit/s links with  $t_{ta}=0.1$  ms and  $W_{max}=127$ . It shows that, although for low BER the maximum frame size

should be used, a much different frame size value should be used for high BER for maximum throughput. Thus, optimum window size and frame size parameters are of great importance for IrLAP throughput.

## VII. Optimum link parameter values

We can maximise (15) as a function of the link layer parameters by examining its first derivative. Throughput analysis presented in previous section revealed the importance of physical layer's minimum turn around time. Optimum  $t_{Fout}$  timer value must first be explored for maximum throughput in high BER.

Equation (5) reveals that if the link BER  $p_b$  is increased, frame error probability  $p$  is significantly increased. In such a case, the time spent on primary's F-timer expiration, represented in (9) by term  $pt_{Fout}$ , may significantly increase the average WTT resulting in throughput performance degradation. IrLAP specification [9] poses only an upper limit of 500ms for  $t_{Fout}$  timer and allows implementation of a smaller value. According to IrLAP specification [9], if the secondary has information ready for transmission, it sets the F-bit in the last I-frame it transmits. Otherwise, upon gaining transmission control, it immediately transmits an S-frame with F-bit set, thus acknowledging I-frames correctly received and reversing link direction. Thus, the secondary station never holds transmission control without transmitting I-frames. As a result,  $t_{Fout}$  value may be safely reduced from the value of 500ms to the smaller time required for the secondary to transmit a full window (N) of full payload (16Kbits) I-frames plus the time required for reversing the link direction twice,  $t_{Fout} = Nt_{imax} + 2t_{ia}$ . This value assumes that the secondary has transmitted a full window of I-frames and the primary did not manage to correctly receive a single I-frame. In the saturation case considered in the current work, the secondary station never transmits I-frames to the primary and immediately acknowledges I-frames correctly received by means of an S-frame transmission. As a result, a smaller  $t_{Fout}$  value of  $t_{Fout} = t_{imax} + 2t_{ia}$  may be safely implemented in the current scenario. This value allows the secondary station to transmit an S-frame or an I-frame if it wishes to transmit information at the end of information transfer from the primary to the secondary station. This  $t_{Fout}$  value is valid since it corresponds to a maximum window size parameter of one for the secondary station negotiated and agreed during link establishment. Optimum  $t_{Fout}$  value becomes of key importance for maximum throughput at high BER if optimum link parameter values are implemented by the primary station. Fig. 11 shows time allocation of

various IrLAP tasks versus BER when optimum window size  $N$  is implemented for  $t_{Fout}=500\text{ms}$ . At high BER, a significant amount of time is spent on F-timer expiration causing serious throughput degradation. It can be easily observed that time spent on  $t_{Fout}$  expiration is much larger than time spent on retransmitting error or correctly received out of sequence frames, on reversing link direction etc. The situation is explained by considering that a single I-frame transmission error results in a significant 500ms delay if the lost I-frame contains the P-bit. For the saturation case considered, if the maximum window size allowed for the secondary is agreed to be equal to one and  $t_{Fout} = t_{Imax} + 2t_{ta}$ , a much different behaviour is shown in Fig. 12. A high throughput performance is achieved over a wider BER mainly by taking advantage of time otherwise wasted of  $t_{Fout}$  timer expiration. Unless otherwise specified, the  $t_{Fout}$  value implemented in current work is given by

$$t_{Fout} = t_{Imax} + 2t_{ta} \quad (22)$$

A different approach to address the significance of  $t_{Fout}$  is obtained by reducing the probability of P-bit loss rather than dealing with the time wasted for every P-bit loss. According to the IrLAP specification primary state charts [9], the primary station sets the P-bit of the last I-frame in a window transmission. This decision assumes that line BER is very low and frame error probability  $p$  is very small. Thus, P-bit is seldom lost and time spent on  $t_{Fout}$  timer expiration is negligible. However, if line BER is relatively high,  $p$  is significantly increased as it usually refers to an I-frame with 16Kbits of user data. To reduce the probability of P-bit loss, a slight IrLAP modification may be employed. The primary should not set the P-bit in the last I-frame it transmits, but transmit the P bit in a new RR S-frame after the last I-frame transmission. As S-frames are very small, they introduce negligible delays. As S-frames have a very small frame error rate, delays on F-timer are significantly reduced. The model presented in current work can be easily altered to calculate throughput performance in this case. S-frame modification is presented in Fig. 13 and WTT becomes

$$t_w = Nt_I + t_s + t_{ack} \quad (23)$$

independent of the number of errors in the window transmission. The assumption that S-frames are always transmitted error free holds true since the BER is at least two orders of magnitude greater than the S-frame size. Throughput is now given by

$$D_b = l \frac{1-p}{p} \frac{(1-(1-p)^N)}{Nt_I + t_s + t_{ack}} \quad (24)$$

The following analysis for deriving optimum values for window and/or frame size parameters is derived for links not employing the S-frame modifications and using small  $t_{Fout}$  values, such as the value given in (22). Identical formulae have been derived for the S-frame modification (which eliminates F-timer delays) by taking the first derivative of throughput equation (24). Hence the following analysis applies to both cases.

### A. Optimum window size

Due to the half duplex nature of the IrLAP protocol, window size is a very important and easily adjustable parameter. If a large window size value is implemented for high BERs, a large number of frames following a frame incorrectly received may be transmitted. Even if these frames are correctly received, they are considered out of sequence and discarded by the receiver. These frame transmissions essentially delay reversing link direction, acknowledging correctly received frames and retransmitting the erred frame. Time needed for such frame transmissions is simply wasted. To derive optimum window size values, the derivative of (15) against  $N$  must be set to zero. First considering the valid approximation for small  $p$ ,

$$(1-p)^N \approx 1 - Np + \frac{N(N-1)}{2} p^2 \quad (25)$$

the derivative of (15) becomes

$$\frac{\partial D_f}{\partial N} = \frac{l}{p+1} \frac{1-p}{2} \frac{\partial}{\partial N} \frac{2N - N(N-1)p}{Nt_I + \frac{2pt_{ta} + pt_s + t_{ack}}{p+1}} = 0 \quad (26)$$

After some algebra and assuming  $\frac{2pt_{ta} + pt_s + t_{ack}}{p+1} \approx t_{ack}$

$$(-pt_I)N^2 + (-2pt_{ack})N + 2t_{ack} + pt_{ack} = 0 \quad (27)$$

Assuming  $pd \ll 2t_{ack}$  and  $-2pt_{ack} < -pt_I$ , (27) becomes

$$(-pt_I)N^2 + 2t_{ack} = 0 \quad (28)$$

and

$$N_{opt} = \sqrt{\frac{2t_{ack}}{pt_I}} \quad (29)$$

Considering the valid approximations for small  $p_b$  and  $l \gg l'$ ,  $p \approx lp_b$  and  $t_I \approx \frac{l}{C}$ , optimum window size value is given by

$$N_{opt} = \sqrt{\frac{2t_{ack}C}{l^2 p_b}} \quad (30)$$

Fig. 14 shows the optimum window size values versus BER for fixed frame size. Window size should be decreased with the increase of BER for maximum throughput. To validate the approximations used to derive (30), Fig. 14 also compares optimum window size values derived from (30) with results obtained using exact numerical methods for a 16Mbit/s link with  $t_{ta}=0.1$ ms and for a 4Mbit/s link with  $t_{ta}=1$  ms.

## B. Optimum frame size

A different approach for reducing information transmitted in a window transmission is by decreasing frame size. A smaller frame size reduces frame error probability and the necessity for retransmissions. However, as each frame transmission requires the transmission of flags, address field, control field and FCS, employing smaller frame sizes results in relative increase of overheads. Frame size adjustment may require buffer reorganisation if adjustment on retransmissions is implemented. Thus, optimum frame size implementation is more difficult than optimum window size implementation but it may also be employed for achieving maximum throughput performance.

The following approximations are considered for small  $p$

$$p = 1 - (1 - p_b)^{l+l'} \approx 1 - (1 - (l+l')p_b) = (l+l')p_b \quad (31)$$

$$\frac{1-p}{p} = \frac{1}{p} - 1 \approx \frac{1}{p} \quad (32)$$

$$(l+l')p_b t_{Fout} = 0 \quad (33)$$

$$(l+l')p_b t_s = 0 \quad (34)$$

$$1 - (1 - (l+l')p_b)^N \approx N(l+l')p_b - \frac{N(N-1)}{2}(l+l')^2 p_b^2 \quad (35)$$

and  $D_b$  is given, in good approximation, by

$$D_b = \frac{C}{2Np_b} l \frac{2Np_b - N(N-1)(l+l')p_b^2}{(l+l') + \frac{t_{ack}C}{N}} \quad (36)$$

The derivative against  $l$  is taken, set equal to zero and after some algebra, we derive that optimum frame size values are given to a in good approximation as:

$$l_{opt} = \sqrt{\frac{2(Nl' + t_{ack}C)}{N^2 p_b}} \quad (37)$$

Fig. 15 shows optimum frame size values versus BER for a fixed window size of 127. As expected, frame size should be decreased for high BERs if maximum throughput is to be achieved. As in the case of optimum window size, all approximations assumed in deriving (37) are validated by comparing optimum values given from (37) with optimum values derived by employing numerical methods for a 16Mbit/s link with  $t_{ta}=0.1$ ms and for a 4Mbit/s link with  $t_{ta}=1$  ms.

An important conclusion can be extracted by observing that (30) and (37) for optimum values can be rewritten as

$$Nlp_b \frac{Nl}{2} = t_{ack}C + Nl' \quad (38)$$

Equation (38) reveals that maximum throughput is achieved when the probability of a bit error in a window frame transmission ( $\approx Nlp_b$ ), times the numbers of bits that have to be retransmitted due to the error occurred, which on average is half the window  $Nl/2$ , is equal to the acknowledgement time in bits  $t_{ack}C$  plus the number of overhead bits in the window  $Nl'$ .

The term  $Nl'$  is missing from (30) because, if optimum window size values are implemented, optimum  $N$  becomes relatively small for high BERs, so term  $Nl'$  can safely be neglected.

### C. Simultaneous Optimisation of window and frame size

If window and frame size link parameters can be simultaneously adjusted, the highest throughput performance can be achieved by taking  $\frac{\partial D_b}{\partial N} = \frac{\partial D_b}{\partial l} = 0$ . To derive optimum  $N$  and  $l$  values, throughput derivative versus  $N$  can be taken following the analysis in section A. Optimum  $N$  values derived by setting the derivative equal to zero can be substituted to throughput equation.

Throughput  $D_b$  is now a function of frame size  $l$  for optimum  $N$  values. The derivative versus  $l$  can now be taken and set equal to zero to derive optimum  $l$  values.  $N_{opt}$  given by (29) should be used as the assumption  $l \gg l'$  is no longer valid as optimum  $l$  values may be significantly small.

$$N_{opt} = \sqrt{\frac{2t_{ack}}{pt_I}} \approx \sqrt{\frac{2t_{ack}}{(l+l')p_b \frac{l+l'}{C}}} = \sqrt{\frac{2t_{ack}C}{(l+l')^2 p_b}} \quad (39)$$

and

$$N_{opt}(l+l') = \sqrt{\frac{2t_{ack}C}{p_b}} = c \quad (40)$$

Considering (5), throughput equation (15) can be rewritten as

$$D_b = \frac{l(1-p)}{p} \frac{(1-(1-p_b)^{N(l+l')})}{N \frac{l+l'}{C} + p(t_{Fout} + t_s) + t_{ack}} \quad (41)$$

Considering (5) and (40)

$$D_b = \frac{l(1-p)}{p} \frac{(1-(1-p_b)^c)}{\left(\frac{c}{C} + p(t_{Fout} + t_s) + t_{ack}\right)} \quad (42)$$

Assuming the valid approximation  $p \approx (l+l')p_b$

$$D_b = \frac{(1-(1-p_b)^c)}{\frac{c}{C}} \frac{l(1-(l+l')p_b)}{(l+l')p_b \left(1 + (l+l')p_b \frac{(t_{Fout} + t_s)C}{c} + \frac{t_{ack}C}{c}\right)} \quad (43)$$

Taking  $s = \frac{(t_{Fout} + t_s)C}{c}$ , the derivative versus  $l$  and by setting it to zero

$$(-2lp_b - (l'p_b - 1)) \left( (l+l')^2 p_b^2 s + (l+l')p_b \left(1 + \frac{t_{ack}C}{c}\right) \right) + (l^2 p_b + l(l'p_b - 1)) \left( 2(l+l')p_b^2 s + p_b \left(1 + \frac{t_{ack}C}{c}\right) \right) = 0 \quad (44)$$

Considering the valid approximation  $l'p_b \approx 0$ , we reach, after some algebra

$$-l^2 p_b \left( s + 2l' p_b s + 1 + \frac{t_{ack}C}{c} \right) + p_b l \left( -2l'^2 p_b s - 2l' \left( 1 + \frac{t_{ack}C}{c} \right) \right) + l'^2 p_b s + l' \left( 1 + \frac{t_{ack}C}{c} \right) = 0 \quad (45)$$

$$\text{As } -2l'^2 p_b s - 2l' \left( 1 + \frac{t_{ack}C}{c} \right) \approx 0$$

$$l_{opt}^2 = \frac{l' \left( l' p_b s + 1 + \frac{t_{ack} C}{c} \right)}{p_b \left( s + 2l' p_b s + 1 + \frac{t_{ack} C}{c} \right)} \quad (46)$$

and, to a very good approximation,

$$l_{opt} \approx \sqrt{\frac{l'}{p_b}} \quad (47)$$

By substituting (47) to (40)

$$N_{opt} \approx \sqrt{\frac{2t_{ack} C}{l'}} \quad (48)$$

Fig. 16 plots optimum window and frame size for 4Mbit/s links with  $t_{ta}=0.1$ ms. It is observed that for a high range of BERs (less than  $10^{-6.5}$ ), (47) suggests that frame size values greater than 16Kbits (the maximum allowed for IrLAP) should be employed. For this range, optimum  $N$  values are given by (30) instead of (48) as optimum frame size values are constant. As a very good match between values given by (47) and (48) and optimum values derived by using numerical methods is observed, approximations made to derive (47) and (48) are validated. Slight differences are observed mainly because optimum  $N$  values given by the mathematical analysis and (48) are real values and have to be rounded as  $N$  can, of course, take only integer values. These differences result in negligible difference in throughput efficiency as shown in Fig. 17.

An important conclusion can be extracted by observing that (30) and (47) for optimum values can be rewritten as

$$N l p_b \frac{N l}{2} = t_{ack} C \quad (49)$$

$$l l p_b = l' \quad (50)$$

Equation (50) reveals that optimum throughput is achieved when the probability of a bit error in a frame ( $\approx l p_b$ ), times the number of frame bits that have to be retransmitted due to this error ( $\approx l$ ) must be equal to the frame bit overhead  $l'$ . This equation shows that optimum frame size values should balance between time spent on retransmitting error frames and time spent on transmitting overheads. Equation (49) shows that maximum throughput is achieved when the probability of a bit

error in a window frame transmission ( $\approx Nlp_b$ ), times the numbers of bits that have to be retransmitted in the following frames due to the error occurred, which on average is half the window  $Nl/2$ , is equal to the acknowledgement time in bits  $t_{ack}C$ . In other words, the bits transmitted in a window transmission,  $Nl$ , should balance between time spend in retransmitting out of sequence frames and on time spend on acknowledgements.

### VIII. Throughput analysis using optimum link parameter values

Fig. 18 compares the throughput efficiency of a 16Mbit/s link with  $t_{ta}=0.1\text{ms}$  employing  $N=127$  and  $l=16384$  with the efficiency achieved by implementing optimum window size or frame size values given by (30) and (37) respectively. Throughput performance for optimum  $N$  values is higher than throughput performance for optimum  $l$  values for low BER because as window size is decreased, fewer frame overheads  $l'$  are transmitted. Implementing the suggested modification in section VII and setting the P-bit in a special RR S-frame is always beneficial as it eliminates time spent on  $t_{Fout}$  timer. Applying optimum window and frame size simultaneous optimisation always results in better performance. Fig. 19 shows the result of reducing  $t_{ta}$  to 0.01ms for the same link speed. A throughput increase is observed, especially for the link implementing optimum window and frame size values. This is due to the increased link turnaround frequency when optimum window and frame size values are employed. In this case, a very high throughput efficiency is observed even for a line BER of  $10^{-5}$  as compared to a line BER of  $10^{-7}$  for the link employing  $l=16\text{Kbits}$  and  $N=127$ . Fig. 20 shows the percentage of time used for various tasks for this link and reveals that the retransmission of correctly received out of sequence frames is of no importance any more as optimum window and frame size employment reduced the probability of transmitting out of sequence frames. It also shows that  $t_{Fout}$  value becomes again of great importance for very high BER. If the P-bit is transmitted on a special S-frame, as suggested in section VII, a significant increase in throughput efficiency is observed as shown in Fig. 21. For links employing a small  $t_{ta}$  of 0.01ms and by implementing the proposed S-frame modification, throughput efficiency of 65% can be achieved even for a  $10^{-4}$  BER by employing optimum widow and frame size values!

## IX. Conclusions

The mathematical model and analysis presented has demonstrated that the concept of ‘window transmission time’ can be applied to the study of IrLAP throughput performance. The model leads to simple formulas for IrLAP link layer throughput and illuminates on the time consuming tasks and delays involved in IrLAP operation. The derived formulas relate throughput and delays with parameters such as link BER, link data rate, minimum turn around time, frame size, and window size. Throughput results are presented for different link parameters. The significance of minimum turn around time delay on throughput is revealed and explored for different IrDA links. Small minimum turn around delays should be implemented if maximum throughput is to be achieved. The effectiveness of the proposed larger window size of 127 frames for the 16Mbit/s links becomes questionable as it slightly increases throughput in low BER but renders link operation very vulnerable to BER increase. The importance of F-timer value is also explored for high BER. Mathematical analysis allows us to derive optimum window and frame size values for any BER. Results indicate that throughput performance is highly improved by use of simultaneously optimum window and frame size value employment. This suggests that adaptive algorithms for modifying window size and frame length would be beneficial for high BER. A protocol improvement that utilises special RR-frames to pass transmission control is proposed. Special RR-frame employment eliminates delays due to  $t_{Fout}$  timer expiration and significantly improves link layer throughput when optimum window and frame size values are simultaneously employed. We believe that the analytical results and optimum values derived can be very useful to link designers in determining the effectiveness of physical and link layer parameters in IrDA link performance.

## References

- [1] D. J. T. Heatly, D. R. Wisely, I. Neild, & P. Cochrane, 'Optical Wireless: The Story So Far'. *IEEE Communications Magazine*, **36**(12), 72-82 (1998).
- [2] A. C. Boucouvalas, Z. Ghassemlooy, Editorial, Special Issue on Optical Wireless Communications, *IEE Proceedings J, Optoelectronics*, **147**, 279, (2000).
- [3] Williams S., 'IrDA: Past, Present and Future', *IEEE Personal Communications*, **7**(1), 11-19 (2000)
- [4] I. Millar, M. Beale, B. J. Donoghue, K. W. Lindstrom, & S. Williams, 'The IrDA Standard for High-Speed Infrared Communications'. *The Hewlett-Packard Journal* 1998; 49(1):10-26.
- [5] IrDA, *Serial Infrared Physical Layer Specification – Version 1.3*, Infrared Data Association, (1998)
- [6] IrDA, *Serial Infrared Physical Layer Specification – Version 1.0*, Infrared Data Association, (1994)
- [7] IrDA, *Serial Infrared Physical Layer Specification – Version 1.1*, Infrared Data Association, (1995)
- [8] IrDA, *Serial Infrared Physical Layer Specification for 16Mb/s Addition (VFIR) – Errata to version 1.3*, Infrared Data Association, (1999)
- [9] IrDA: *Serial Infrared Link Access Protocol (IrLAP) – Version 1.1*, Infrared Data Association, (1996).
- [10] IrDA: *Serial Infrared Link Access Protocol Specification for 16Mb/s Addition (VFIR) – Errata to version 1.1*, Infrared Data Association, (1999).
- [11] Barker P., Boucouvalas A.C. & Vitsas V., "Performance Modelling of the IrDA Infrared Wireless Communications Protocol", *International Journal of Communication Systems* 2000, **13**:589-604.
- [12] Barker P. & A.C. Boucouvalas, 'Performance Analysis of the IrDA protocol in wireless communications' *1st International Symposium on Communication Systems and Digital Signal Processing*, 6-8 April 1998, pp. 603-606, 6-9, Sheffield, UK
- [13] Bux W. & K. Kummerle, 'Balanced HDLC Procedures: A Performance Analysis'. *IEEE Transactions On Communications*, **com-28**(11), pp 1889-1898. (1980).

- [14] Williams S. & Millar I., 'The IrDA platform', *2<sup>nd</sup> international Workshop on Mobile Multimedia Communications*, April 11-14, 1995, Bristol university, UK
- [15] Vitsas V. & A. Boucouvalas, 'Throughput Analysis of the IrDA IrLAP Optical Wireless Link Access Protocol' *3<sup>rd</sup> Conference on Telecommunications, Conftele 2001*, pp. 225-229, April 23-24, 2001, Figueira da Foz, Portugal.

## List of Tables and Figures

Table 1: Analysis Parameters

Table 2:  $Nt_l$  and  $t_{ack}$  for SIR and FIR data rates

Figure 1. The IrDA protocol architecture

Figure 2. IrDA frame structure

Figure 3. Information transfer procedure

Figure 4. Determination of window transmission time  $t_w$

Figure 5. Throughput efficiency versus BER for  $t_{ta}=10ms$ ,  $W_{max}=7$ ,  $l=16Kbits$ ,  $t_{Fout}=t_{lmax}+2t_{ta}$

Figure 6. Throughput efficiency versus BER for  $C=16Mbit/s$ ,  $l=16Kbits$ ,  $t_{Fout}=t_{lmax}+2t_{ta}$

Figure 7. Throughput efficiency versus window size for  $C=16Mbit/s$ ,  $t_{ta}=0.1ms$ ,  $l=16Kbits$ ,  $t_{Fout}=t_{lmax}+2t_{ta}$

Figure 8. Throughput efficiency versus window size for  $C=4Mbit/s$ ,  $t_{ta}=10ms$ ,  $l=16Kbits$ ,  $t_{Fout}=t_{lmax}+2t_{ta}$

Figure 9. Time allocation of various IrLAP tasks against BER for  $C=16Mbit/s$ ,  $l=16Kbits$ ,  $t_{ta}=0.1ms$ ,  $N=127$ ,  $t_{Fout}=t_{lmax}+2t_{ta}$

Figure 10. Throughput efficiency versus frame size for  $C=16Mbit/s$ ,  $t_{ta}=0.1ms$ ,  $N=127$ ,  $t_{Fout}=t_{lmax}+2t_{ta}$

Figure 11. Time allocation of various IrLAP tasks against BER for  $N$  optimum,  $t_{Fout}=500ms$ ,  $C=16Mbit/s$ ,  $l=16Kbits$ ,  $t_{ta}=0.1ms$

Figure 12. Time allocation of various IrLAP tasks against BER for  $N$  optimum,  $t_{Fout}=t_{lmax}+2t_{ta}$ ,  $C=16Mbit/s$ ,  $l=16Kbits$ ,  $t_{ta}=0.1ms$

Figure 13. Determination of window transmission time  $t_w$  for setting the P-bit in S-frame

Figure 14. Optimum window size validation

Figure 15. Optimum frame size validation

Figure 16. Optimum window and frame size validation for  $C=4Mbit/s$ ,  $t_{ta}=0.1ms$ ,  $t_{Fout}=t_{lmax}+2t_{ta}$

Figure 17. Throughput efficiency for simultaneous optima  $N$  and  $l$ ,  $C=4Mbit/s$ ,  $t_{ta}=0.1ms$ ,  $t_{Fout}=t_{lmax}+2t_{ta}$

Figure 18. Throughput against BER for 16Mbit/s link,  $t_{ta}=0.1ms$

Figure 19 Throughput against BER for 16Mbit/s link,  $t_{ta}=0.01ms$

Figure 20. Time allocation of various IrLAP tasks against BER for simultaneous optima  $N$  and  $l$ ,  $C=16Mbit/s$ ,  $t_{ta}=0.01ms$ ,  $t_{Fout}=t_{lmax}+2t_{ta}$

Figure 21. Time allocation of various IrLAP tasks against BER for simultaneous optima  $N$  and  $l$ , P-bit in S-frame,  $C=16Mbit/s$ ,  $t_{ta}=0.01ms$

<b>Parameter</b>	<b>Description</b>	<b>Unit</b>
$C$	Link data baud rate	bits /sec
$p_b$	Link bit error rate	-
$p$	Frame error probability	-
$l$	I-frame message data length	bits
$l'$	S-frame length / I-frame overhead	bits
$t_I$	Transmission time of an I-frame	sec
$t_{I_{max}}$	Transmission time of an I-frame with 16Kbits user data	sec
$t_S$	Transmission time of an S-frame	sec
$t_{ta}$	Minimum turn-around time	sec
$t_{ack}$	Acknowledgement time	sec
$T_{max}$	Maximum turn-around time	sec
$t_{Fout}$	F-timer time-out period	sec
$D_f$	Frame throughput	frames/sec
$D_b$	Data throughput	bits/sec

*Table 1: Analysis Parameters*

specification	speed	year	window size (frames)	effective $N$ (frames)	$Nt_l$ (ms)	maximum $t_{ta}$ (ms)	$t_{ack}$ (ms)
SIR	115.2 Kbit/s	1994	7	3	427.9	10	20.00
FIR	576 Kbit/s	1995	7	7	199.7	10	20.00
FIR	1.152 Mbit/s	1995	7	7	99.8	10	20.00
FIR	4 Mbit/s	1995	7	7	28.8	10	20.00
VFIR	4 Mbit/s	1999	127	121	497.8	10	20.00
VFIR	16 Mbit/s	1999	127	127	130.6	0.1	0.20

*Table 2:  $Nt_l$  and  $t_{ack}$  for SIR and FIR data rates*

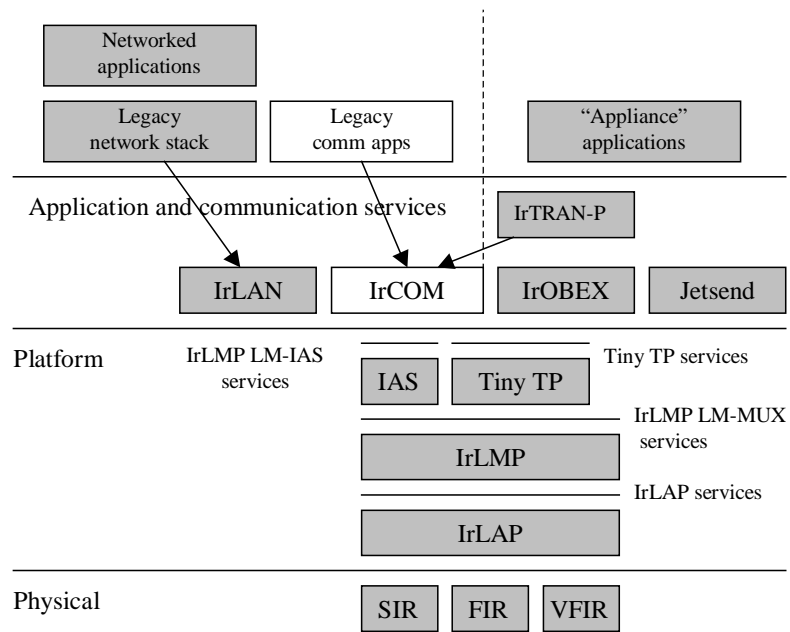

Figure 1 The IrDA protocol architecture

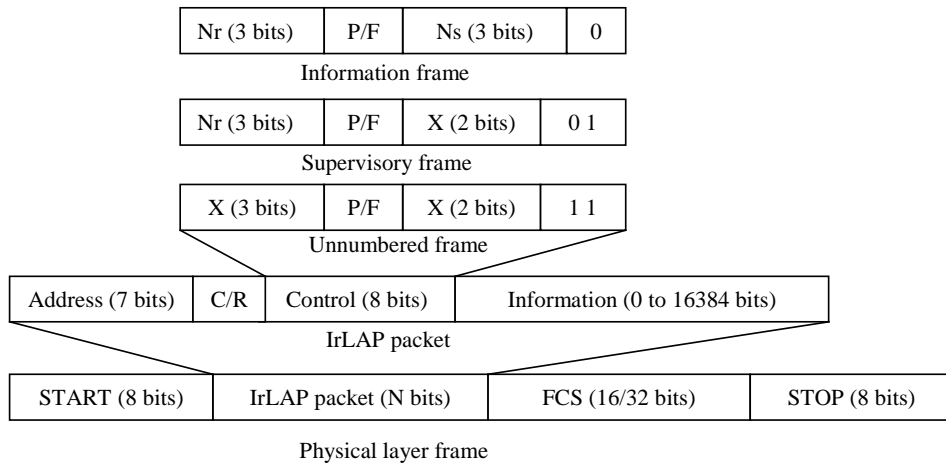

Figure 2: IrDA frame structure

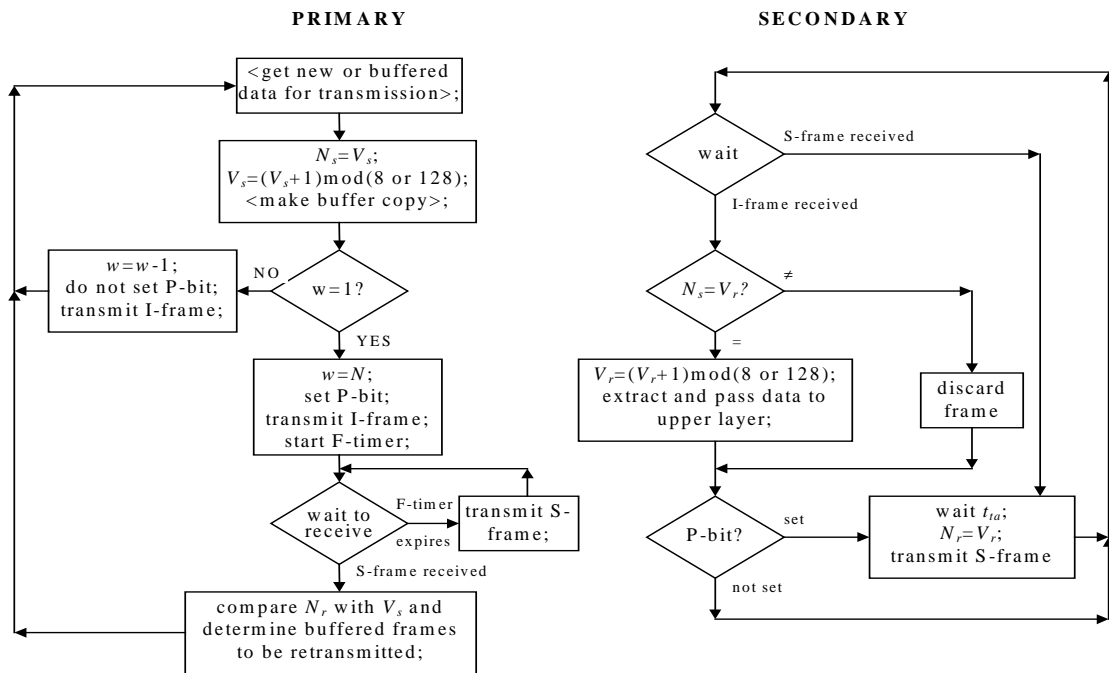
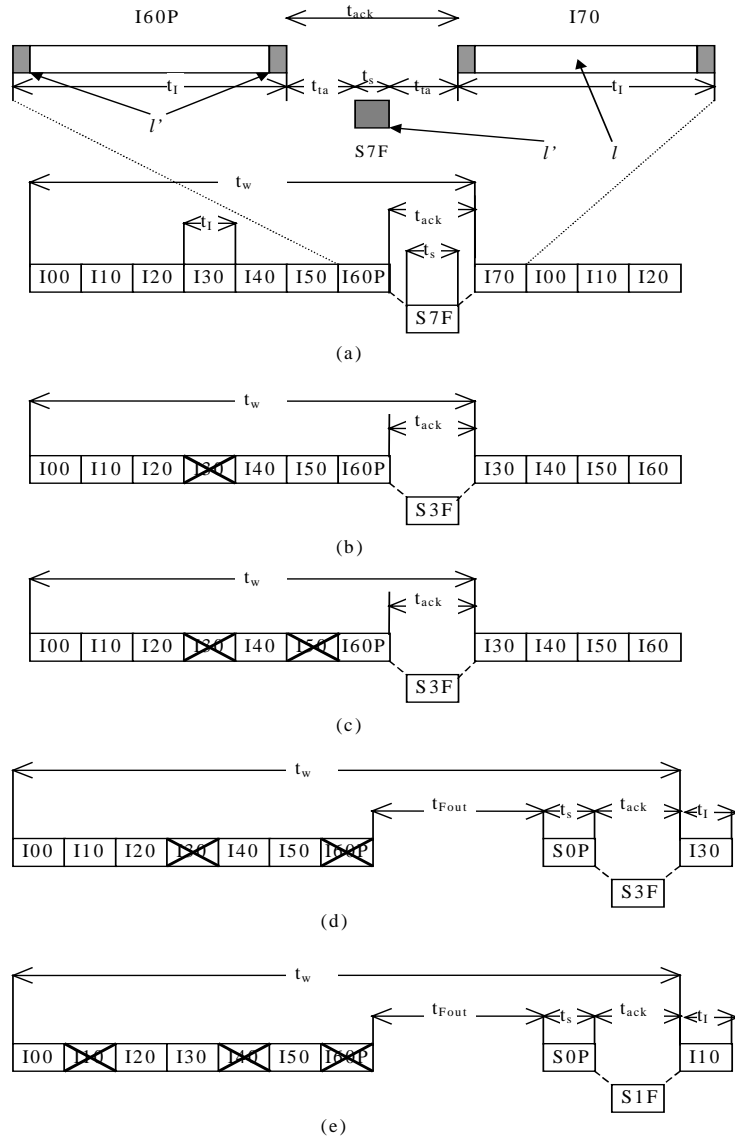

Figure 3. Information transfer procedure



$I_{xy}$  : I-frame with  $N_s=x$  and  $N_r=y$

$I_{xyP}$  : I-frame with  $N_s =x$ ,  $N_r =y$  and P-bit set

$S_xP$  : S-frame with  $N_r =x$  and P-bit set

$S_xF$  : S-frame with  $N_r =x$  and F-bit set

(a) Window error free transmission

(b) Retransmitted frames due to error frame with  $N_s=3$

(c) Retransmitted frames due to error frame with  $N_s =3$  and  $N_s =5$

(d) Retransmitted frames and F-timer delay due frame error at  $N_s =3$  and  $N_s =6$

(e) Retransmitted frames and F-timer delay due frame error  $N_s =1$ ,  $N_s =4$  and  $N_s =6$

Figure 4. Determination of window transmission time  $t_w$

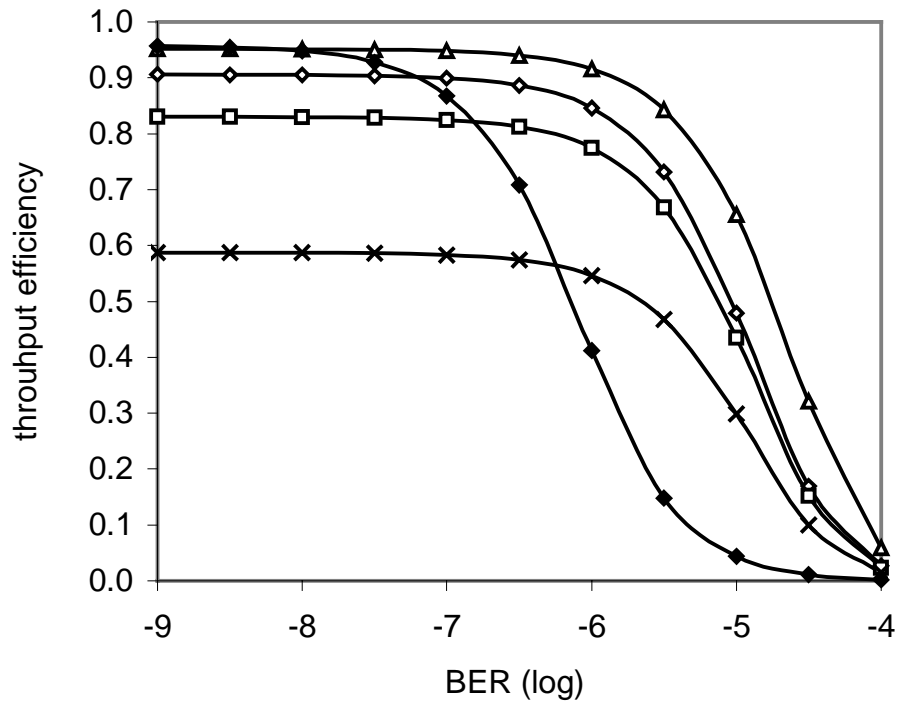

△  $C=115200$  bit/s,  $W_{max}=7$

◇  $C=576000$  bit/s,  $W_{max}=7$

□  $C=1152000$  bit/s,  $W_{max}=7$

×  $C=4$  Mbit/s,  $W_{max}=7$

◆  $C=4$  Mbit/s,  $W_{max}=127$

Figure 5. Throughput efficiency versus BER for  $t_{ta}=10$ ms,  $l=16$ Kbits,  $t_{Fout}=t_{Imax}+2t_{ta}$

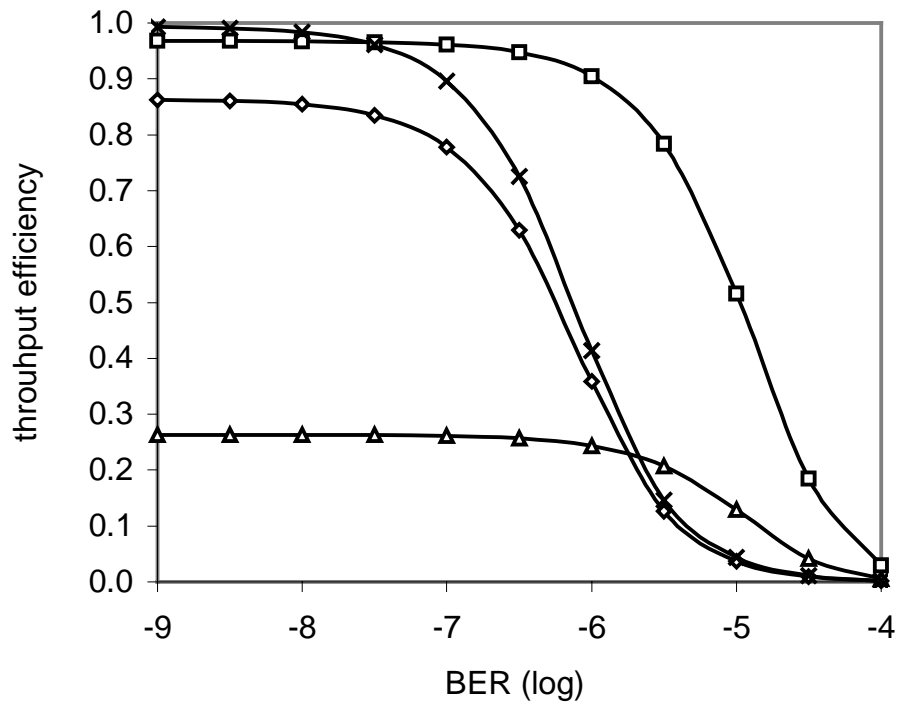

- $\Delta$   $W_{max}=7, t_{ta}=10ms$
- $\diamond$   $W_{max}=127, t_{ta}=10ms$
- $\square$   $W_{max}=7, t_{ta}=0.1ms$
- $\times$   $W_{max}=127, t_{ta}=0.1ms$

Figure 6. Throughput efficiency versus BER for  $C=16Mbit/s, l=16Kbits, t_{Fout}=t_{Imax}+2t_{ta}$

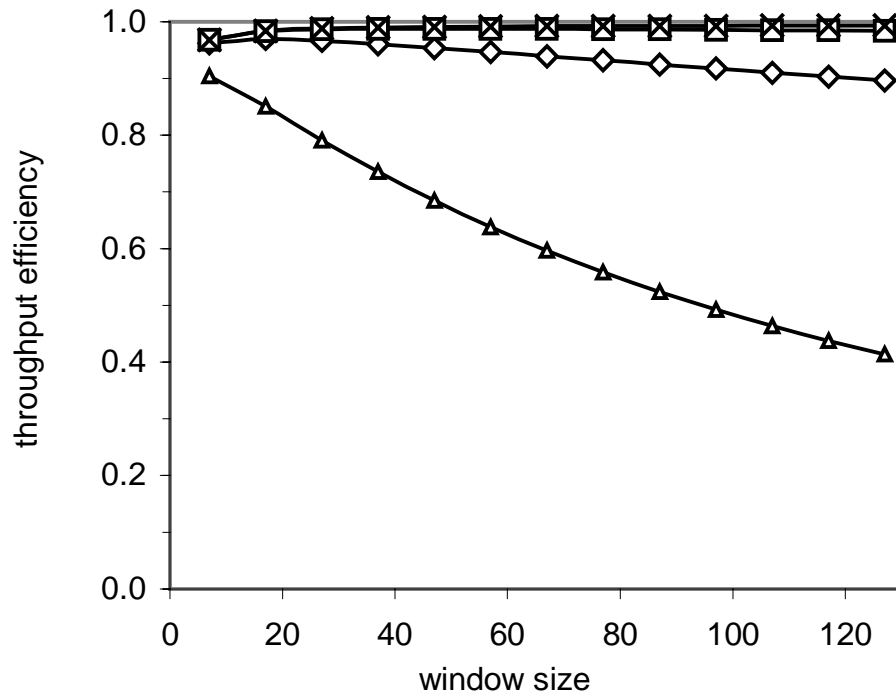

- △  $BER=10^{-6}$
- ◇  $BER=10^{-7}$
- $BER=10^{-8}$
- ×  $BER=10^{-9}$

Figure 7. Throughput efficiency versus window size for  $C=16\text{Mbit/s}$ ,  $t_{ia}=0.1\text{ms}$ ,  $l=16\text{Kbits}$ ,  $t_{Fout}=t_{I_{max}}+2t_{ia}$

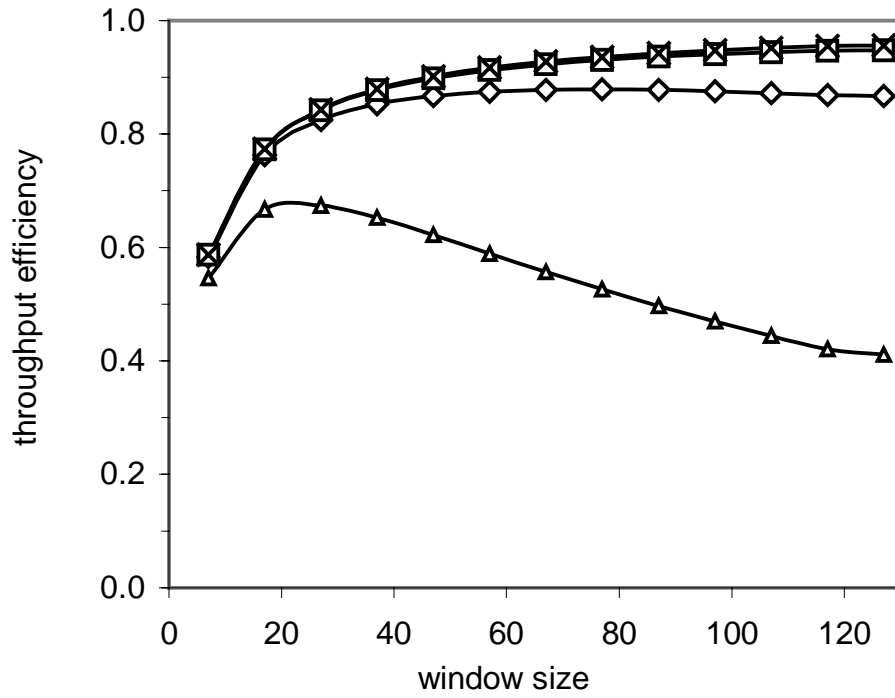

△  $BER=10^{-6}$

◇  $BER=10^{-7}$

□  $BER=10^{-8}$

×  $BER=10^{-9}$

Figure 8. Throughput efficiency versus window size for  $C=4\text{Mbit/s}$ ,  $t_{ia}=10\text{ms}$ ,  $l=16\text{Kbits}$ ,  $t_{Fout}=t_{I\max}+2t_{ia}$

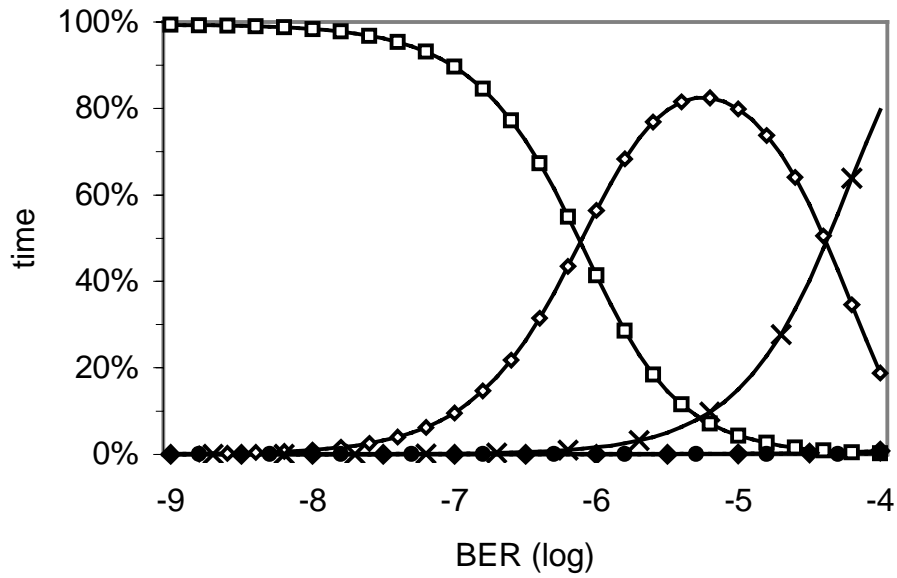

- useful data transmission (throughput efficiency)
- ◇ retransmission of correctly received out of sequence frames
- × retransmission of error frames
- ◆  $t_{Fout}$  timer expiration
- reversing link direction (hardware latency)

Figure 9. Time allocation of various IrLAP tasks against BER for  $C=16\text{Mbit/s}$ ,  $l=16\text{Kbits}$ ,  $t_{ta}=0.1\text{ms}$ ,  $N=127$ ,  $t_{Fout}=t_{Imax}+2t_{ta}$

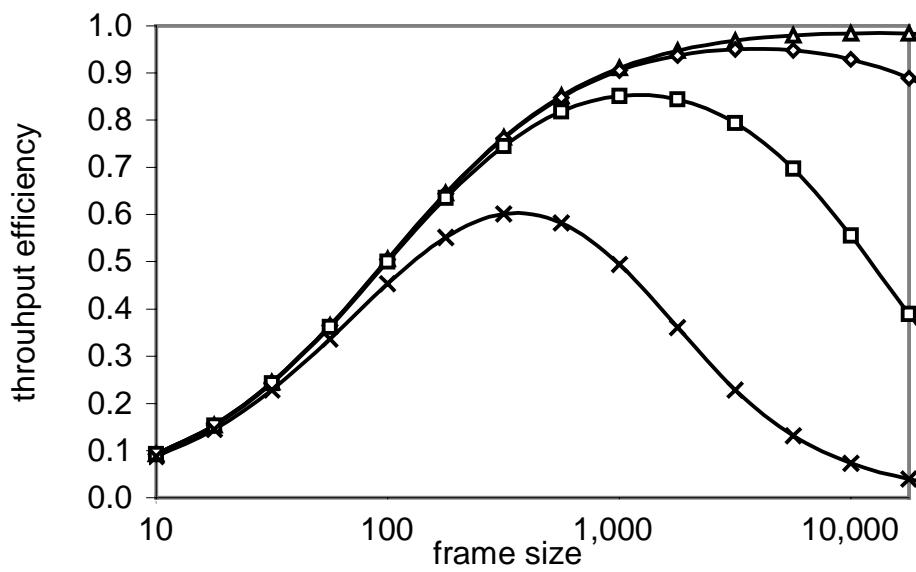

- $\triangle$   $BER=10^{-8}$
- $\diamond$   $BER=10^{-7}$
- $\square$   $BER=10^{-6}$
- $\times$   $BER=10^{-5}$

Figure 10. Throughput efficiency versus frame size for  $C=16\text{Mbit/s}$ ,  $t_{ia}=0.1\text{ms}$ ,  $N=127$ ,  $t_{Fout}=t_{Imax}+2t_{ia}$

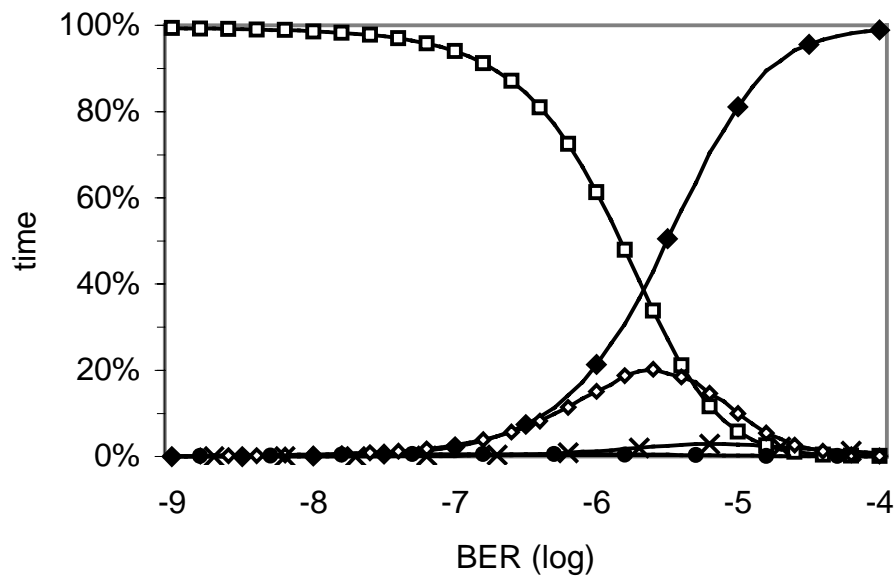

- useful data transmission (throughput efficiency)
- ◇ retransmission of correctly received out of sequence frames
- × retransmission of error frames
- ◆  $t_{Fout}$  timer expiration
- reversing link direction (hardware latency)

Figure 11. Time allocation of various IrLAP tasks against BER for  $N$  optimum,  $t_{Fout}=500ms$ ,  $C=16Mbit/s$ ,  $l=16Kbits$ ,  $t_{ta}=0.1ms$

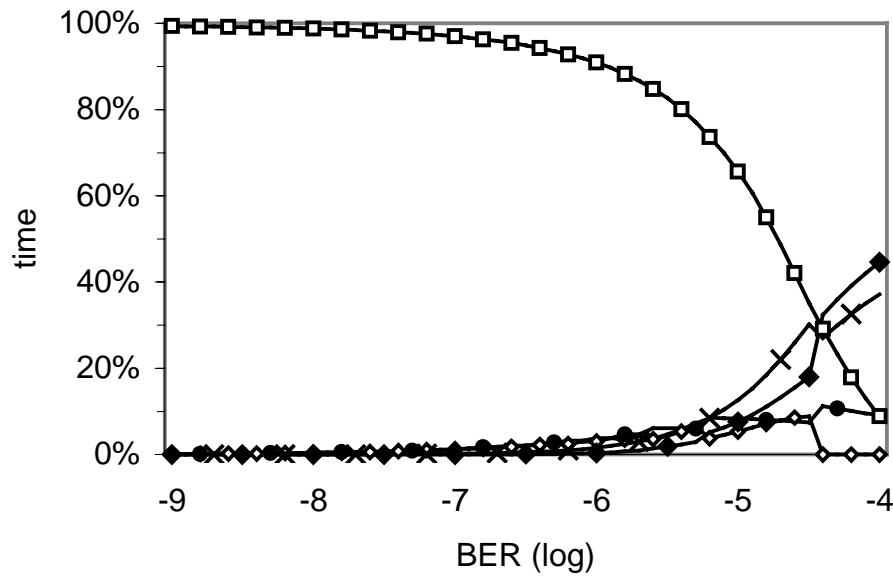

- useful data transmission (throughput efficiency)
- ◇ retransmission of correctly received out of sequence frames
- × retransmission of error frames
- ◆  $t_{Fout}$  timer expiration
- reversing link direction (hardware latency)

Figure 12. Time allocation of various IrLAP tasks against BER for  $N$  optimum,  $t_{Fout} = t_{Imax} + 2t_{ta}$ ,  $C = 16\text{Mbit/s}$ ,  $l = 16\text{Kbits}$ ,  $t_{ta} = 0.1\text{ms}$

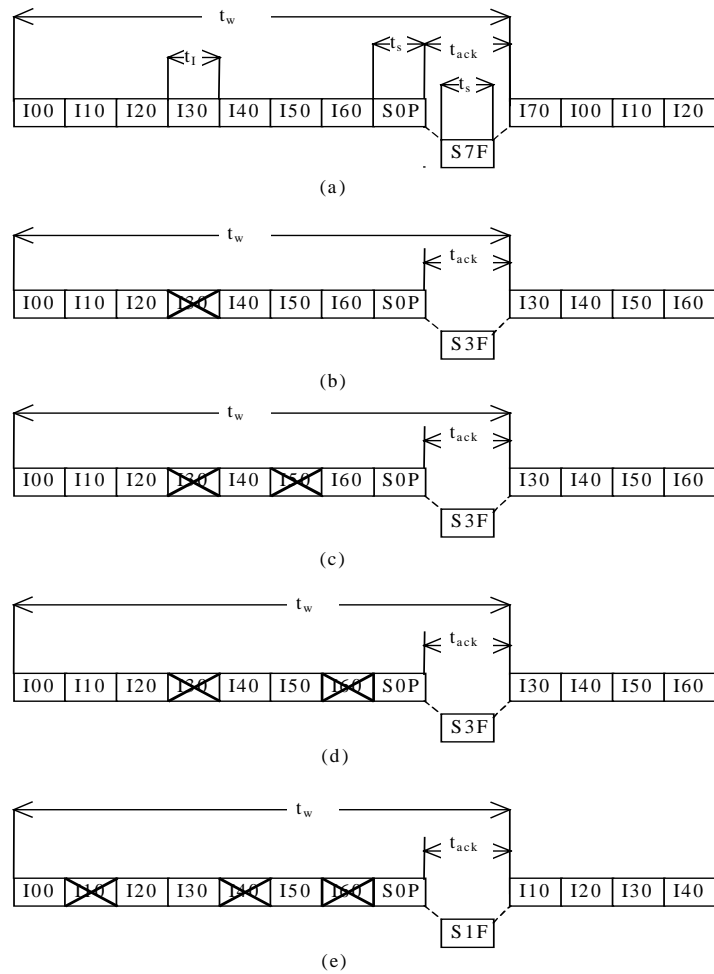

I<sub>xy</sub> : I-frame with  $N_s=x$  and  $N_r=y$

I<sub>xyP</sub> : I-frame with  $N_s =x$ ,  $N_r =y$  and P-bit set

S<sub>xP</sub> : S-frame with  $N_r =x$  and P-bit set

S<sub>xF</sub> : S-frame with  $N_r =x$  and F-bit set

(a) Window error free transmission

(f) Retransmitted frames due to error frame with  $N_s=3$

(g) Retransmitted frames due to error frame with  $N_s =3$  and  $N_s =5$

(h) Retransmitted frames and F-timer delay due frame error at  $N_s =3$  and  $N_s =6$

(i) Retransmitted frames and F-timer delay due frame error  $N_s =1$ ,  $N_s =4$  and  $N_s =6$

Figure 13. Determination of window transmission time  $t_w$  for setting the P-bit in S-frame

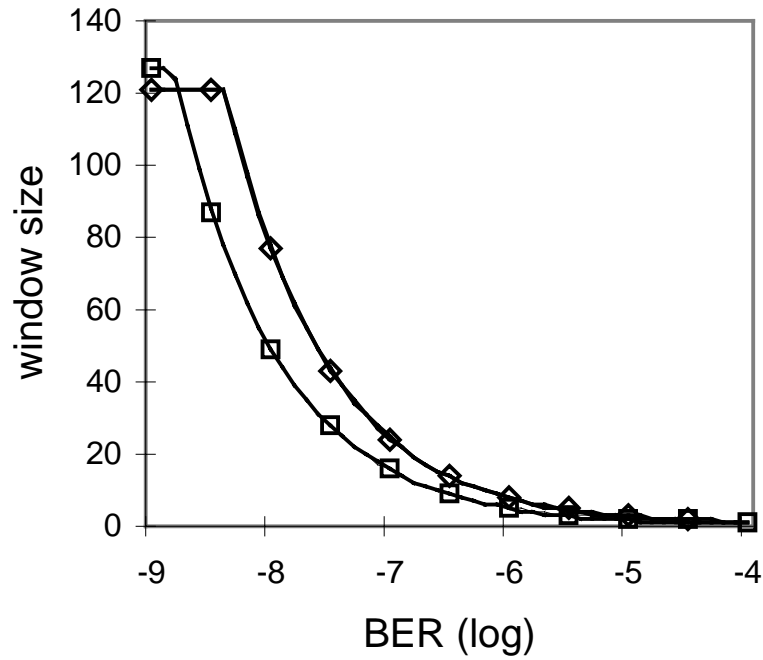

- optimum  $N$  (analysis),  $C=16\text{Mbit/s}$ ,  $t_{ia}=0.1\text{ms}$ ,  $l=16\text{Kbits}$ ,  $t_{Fout}=t_{Imax}+2t_{ia}$
- optimum  $N$  (numerical)  $C=16\text{Mbit/s}$ ,  $t_{ia}=0.1\text{ms}$ ,  $l=16\text{Kbits}$ ,  $t_{Fout}=t_{Imax}+2t_{ia}$
- optimum  $N$  (analysis),  $C=4\text{Mbit/s}$ ,  $t_{ia}=1\text{ms}$ ,  $l=16\text{Kbits}$ ,  $t_{Fout}=t_{Imax}+2t_{ia}$
- ◇ optimum  $N$  (numerical)  $C=4\text{Mbit/s}$ ,  $t_{ia}=1\text{ms}$ ,  $l=16\text{Kbits}$ ,  $t_{Fout}=t_{Imax}+2t_{ia}$

Figure 14. Optimum window size validation

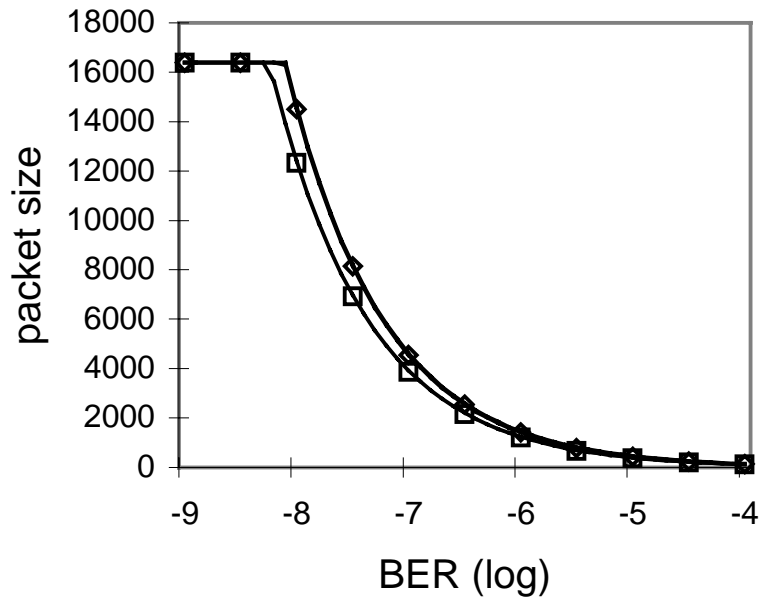

- optimum  $l$  (analysis),  $C=16Mbit/s$ ,  $t_{ta}=0.1ms$ ,  $N=127$ ,  $t_{Fout}=t_{Imax}+2t_{ta}$
  - optimum  $l$  (numerical)  $C=16Mbit/s$ ,  $t_{ta}=0.1ms$ ,  $N=127$ ,  $t_{Fout}=t_{Imax}+2t_{ta}$
  - optimum  $l$  (analysis),  $C=4Mbit/s$ ,  $t_{ta}=1ms$ ,  $N=127$ ,  $t_{Fout}=t_{Imax}+2t_{ta}$
  - ◇ optimum  $l$  (numerical)  $C=4Mbit/s$ ,  $t_{ta}=1ms$ ,  $N=127$ ,  $t_{Fout}=t_{Imax}+2t_{ta}$
- Figure 15. Optimum frame size validation

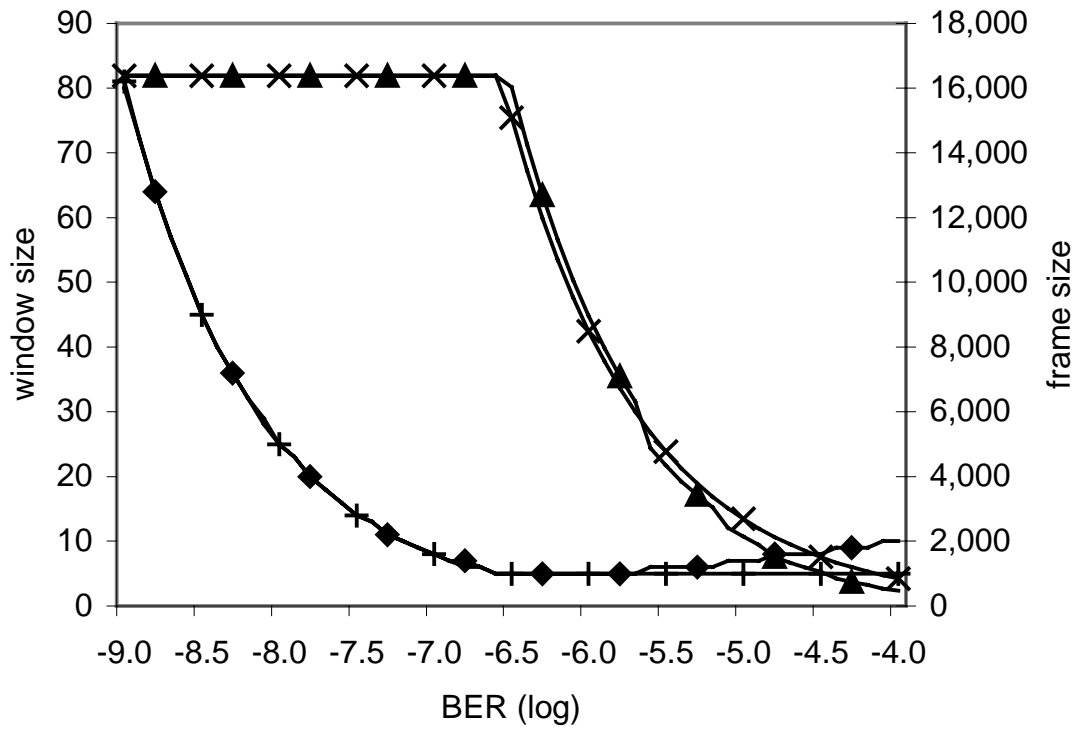

- + optimum  $N$  (analysis)
- ◆ optimum  $N$  (numerical)
- x optimum  $l$  (analysis)
- ▲ optimum  $l$  (numerical)

Figure 16. Optimum window and frame size validation for  $C=4\text{Mbit/s}$ ,  $t_{td}=0.1\text{ms}$ ,  $t_{Fout}=t_{Imax}+2t_{td}$

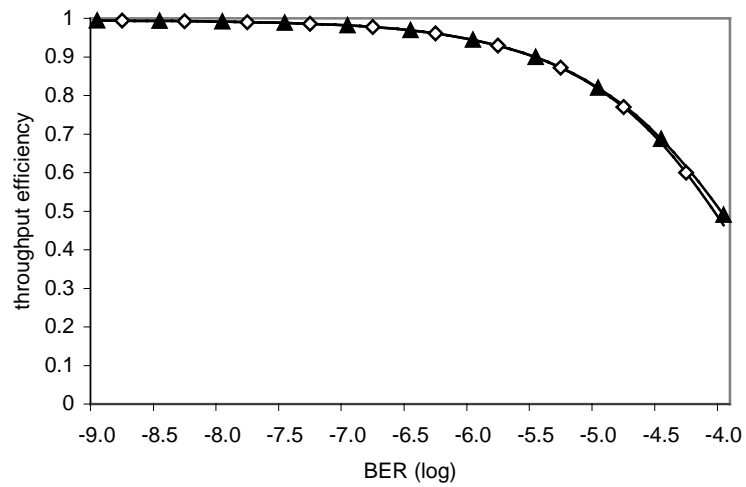

◇ optimum throughput for optimum  $N$  and  $l$  values (analysis)

▲ optimum throughput for optimum  $N$  and  $l$  values (numerical)

Figure 17. Throughput efficiency for simultaneous optima  $N$  and  $l$ ,  $C=4\text{Mbit/s}$ ,  $t_{ta}=0.1\text{ms}$ ,

$$t_{Fout} = t_{I_{max}} + 2t_{ta}$$

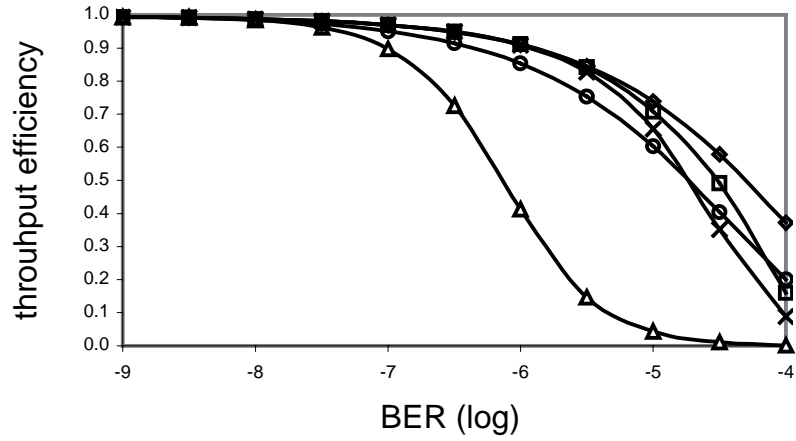

△  $N=127, l=16Kbits, t_{Fout}=t_{lmax}+2t_{ia}$

× optimum  $N, l=16Kbits, t_{Fout}=t_{lmax}+2t_{ia}$

○ optimum  $l, N=127, t_{Fout}=t_{lmax}+2t_{ia}$

□ optimum  $N, P$  bit in RR-frame,  $l=16Kbits$

◆ optimum  $N$  and optimum  $l, t_{Fout}=t_{lmax}+2t_{ia}$

Figure 18. Throughput against BER for 16Mbit/s link,  $t_{ia}=0.1ms$

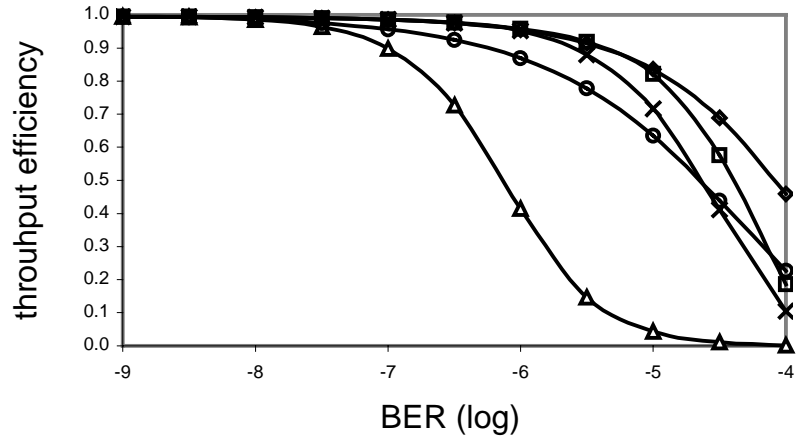

△  $N=127, l=16\text{Kbits}, t_{Fout}=t_{Imax}+2t_{ta}$

× optimum  $N, l=16\text{Kbits}, t_{Fout}=t_{Imax}+2t_{ta}$

○ optimum  $l, N=127, t_{Fout}=t_{Imax}+2t_{ta}$

□ optimum  $N, P$  bit in RR-frame,  $l=16\text{Kbits}$

◆ optimum  $N$  and optimum  $l, t_{Fout}=t_{Imax}+2t_{ta}$

Figure 19 Throughput against BER for 16Mbit/s link,  $t_{ta}=0.01\text{ms}$

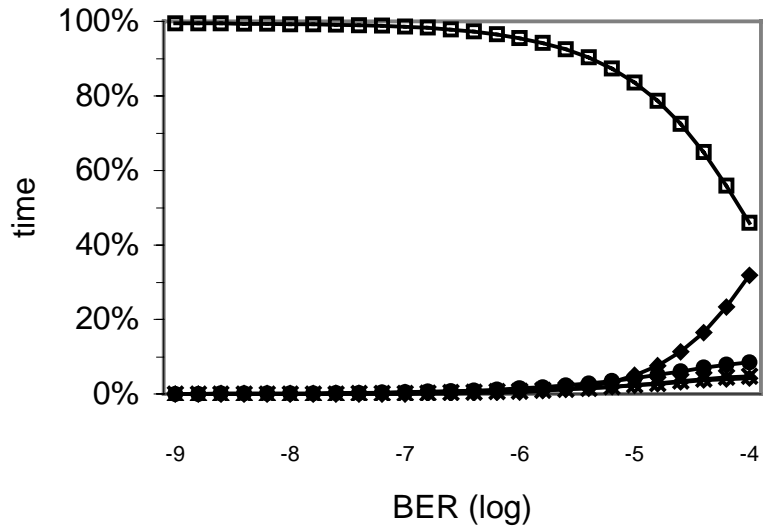

- *useful data transmission (throughput efficiency)*
- ◇ *retransmission of correctly received out of sequence frames*
- × *retransmission of error frames*
- ◆  *$t_{Fout}$  timer expiration*
- *reversing link direction (hardware latency)*

Figure 20. Time allocation of various IrLAP tasks against BER for simultaneous optima  $N$  and  $l$ ,  $C=16\text{Mbit/s}$ ,  $t_{ta}=0.01\text{ms}$ ,  $t_{Fout}=t_{Imax}+2t_{ta}$

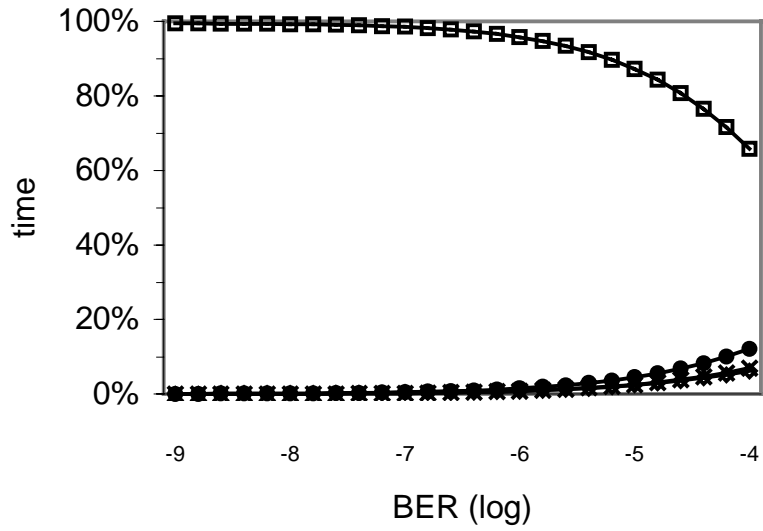

- *useful data transmission (throughput efficiency)*
- ◇ *retransmission of correctly received out of sequence frames*
- × *retransmission of error frames*
- *reversing link direction (hardware latency)*

Figure 21. Time allocation of various IrLAP tasks against BER for simultaneous optima  $N$  and  $l$ ,  $P$ -bit in  $S$ -frame,  $C=16\text{Mbit/s}$ ,  $t_{ia} = 0.01\text{ms}$