



**Bournemouth
University**

Moving from RADs to Use Cases

...and the use of POSD

- Three fundamentally different views, and notation used.
- Process: Role Based. Activities assigned to (and spread across) roles.
- Use Case: Procedural. Actors assigned to (and spread across) major activities.
- Object Oriented. Activities assigned to (cohesive) objects.

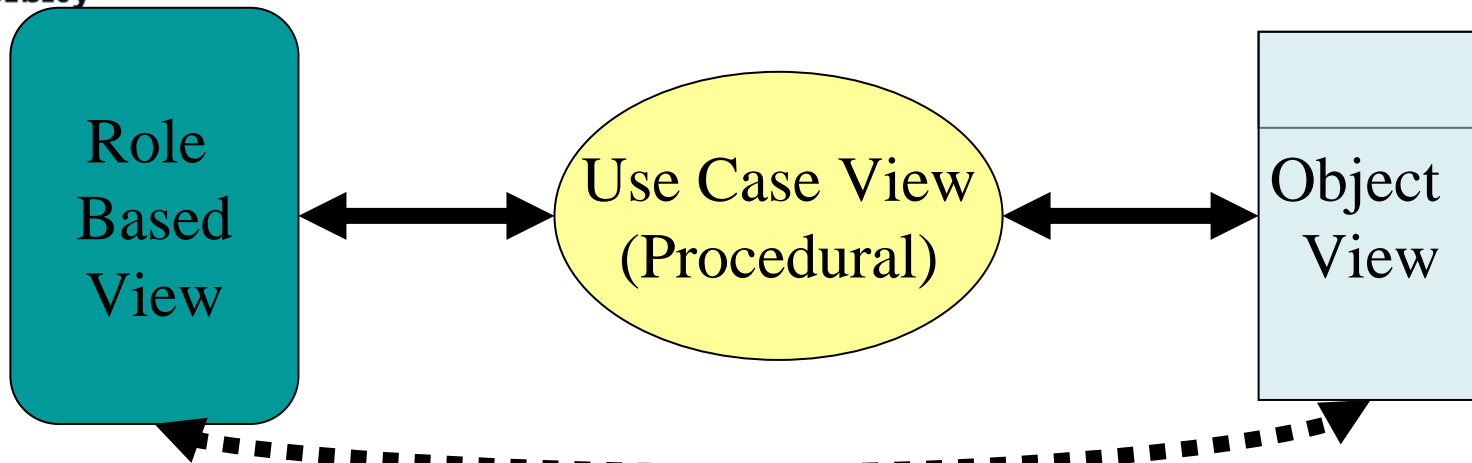

- Difficult to preserve mapping when notations are orthogonal.
 - Sometimes utilise further (structuring and overview) notations, such as POSD.

Initially: Processes to Use Cases

- Role Based. Roles (activities spread).
- Use Case: Abstract activities (actors spread)
- Hence, to map roles to use cases we will need to consider large-scale activities.
 - Typically chunks of interactions, (or actions).
- Hence, Use Cases may be found:
 - In the connections between roles.
 - In the chunks of activity within roles.

- Use Case may be a chunk of connections (bundles of related interactions).
 - Hence, interactions become events within use cases (or whole use cases).
- Similarly, chunks of related actions, or combined activity (actions and interactions).
- Roles often actors (not quite the same).
- May use more abstract mechanisms to handle ‘grouping’ of activities.

Overview Model: POSD For Printing

Simple view of process
Suggests some highly
coupled behaviours (roles).

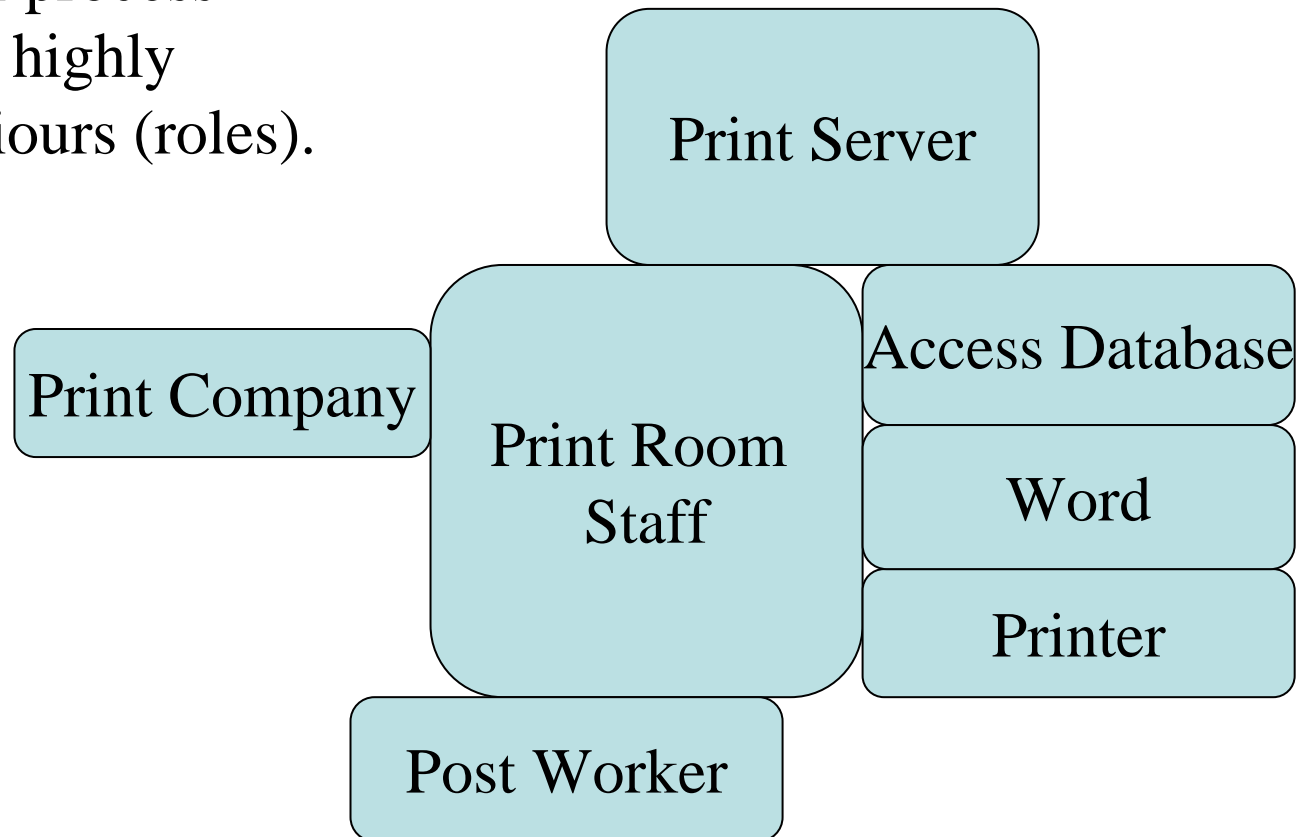

RAD (Process as was)

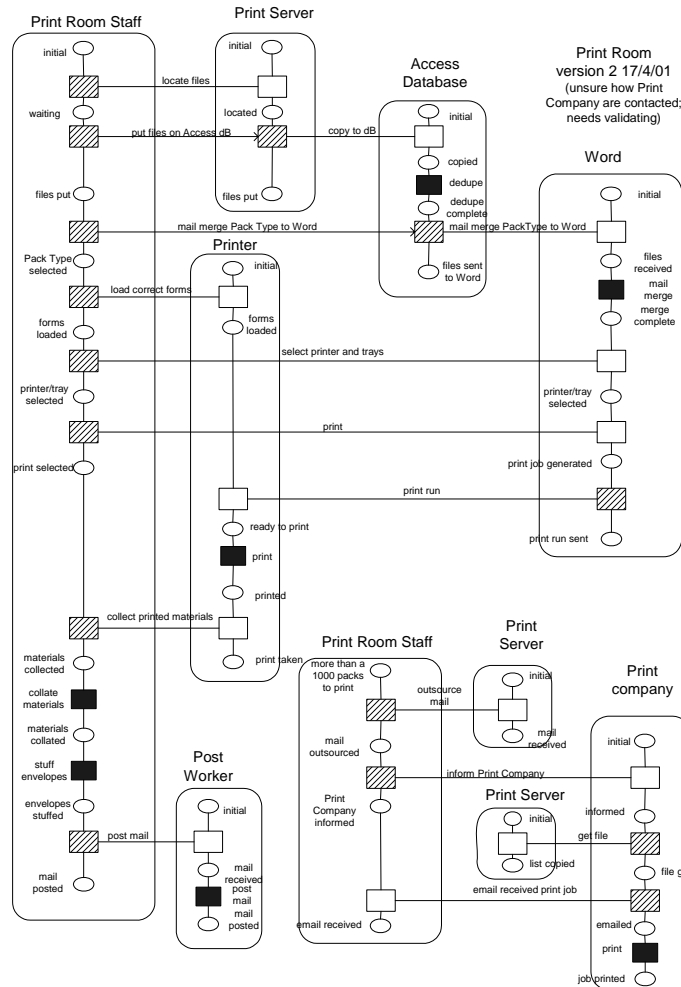

Detailed view of process

Again suggests some highly coupled roles.

Also suggest some complex (multiple-stage) interactions.

- Behaviours (roles) share behaviours with other behaviours (roles) .
- Sometimes behaviour is simple, e.g., an interaction in a RAD.
- Sometimes the behaviour itself is complex and worthy of separate consideration.
 - Behaviours may span roles (or actors or Use Cases).
 - Can depend on perspective. (Email).

Shared Behaviours

	Print Room Staff	Print Server	Access Database	Word	Printer	Post Worker	Print Company
Print Room Staff		I	I	I	I	I	I
Print Server	I		I				
Access Database	I	I		I			
Word	I		I		I		
Printer	I			I			
Post Worker	I						
Print Company	I						

Revised POSD For Printing

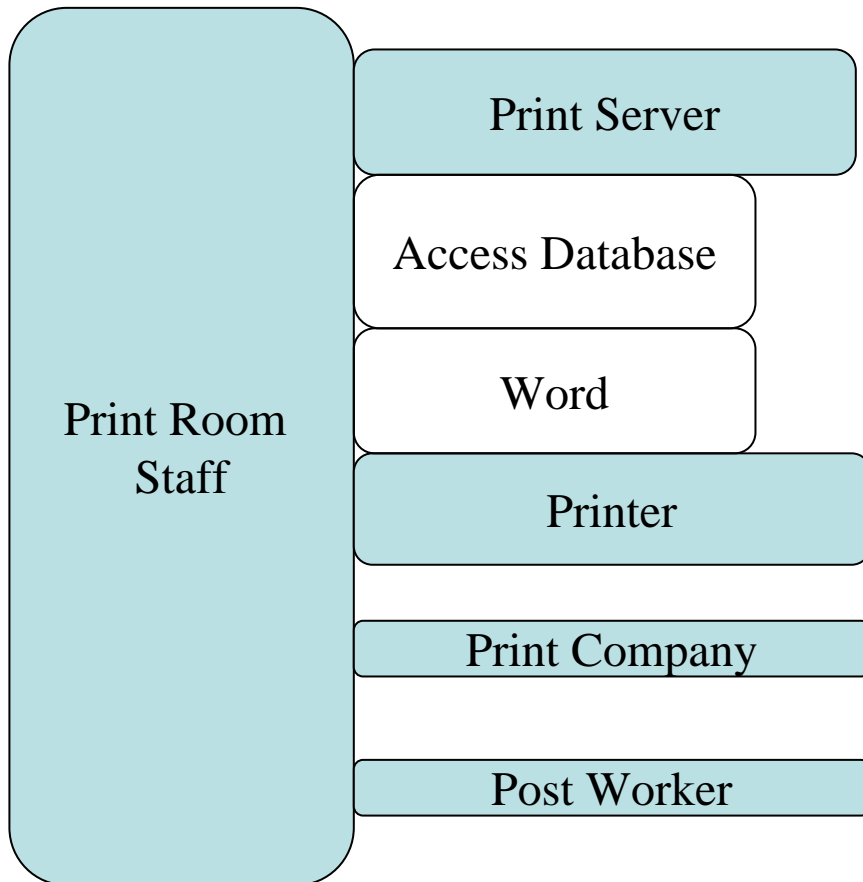

All three views (both POSD and RAD) are consistent in sharing of behaviours.

Note: Access and Word typically considered mechanism (omitted) in process model.

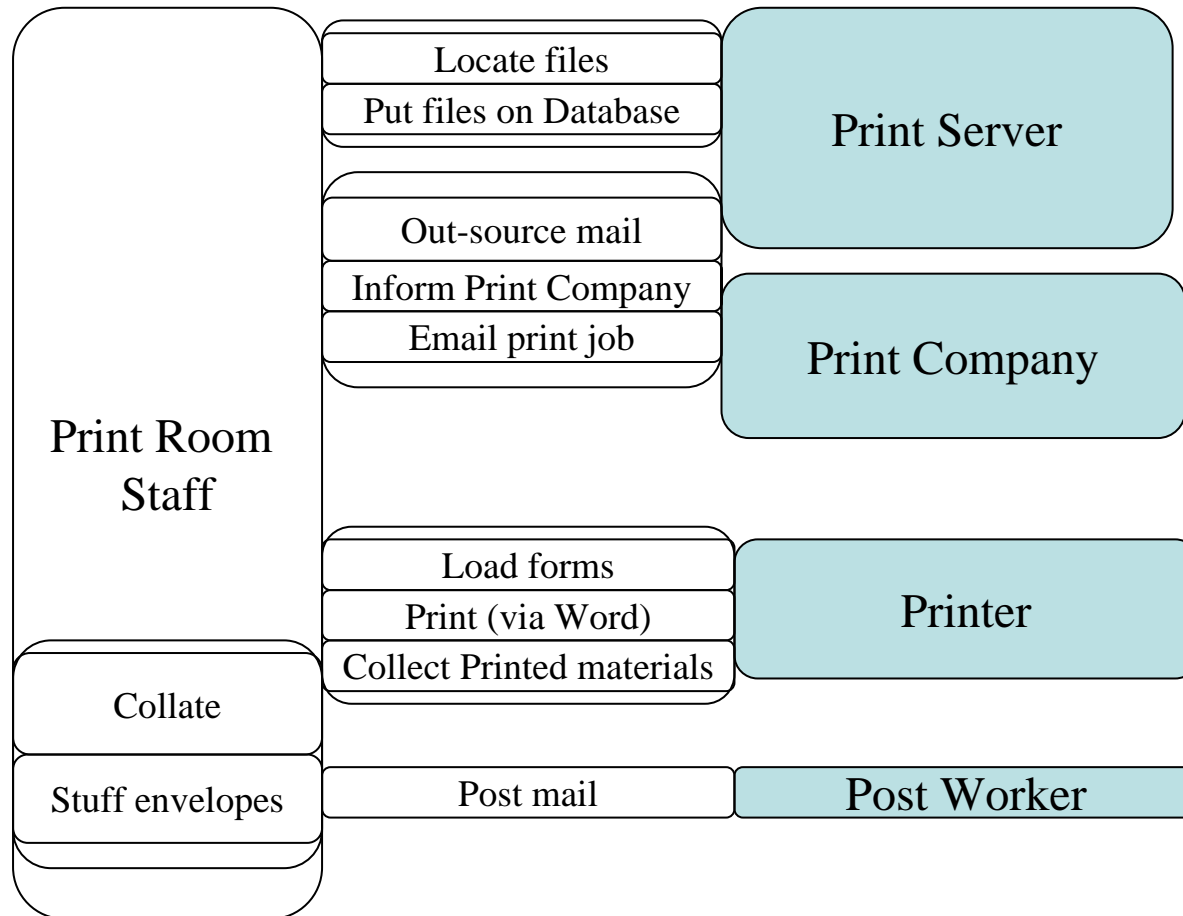

Overview and Sequence

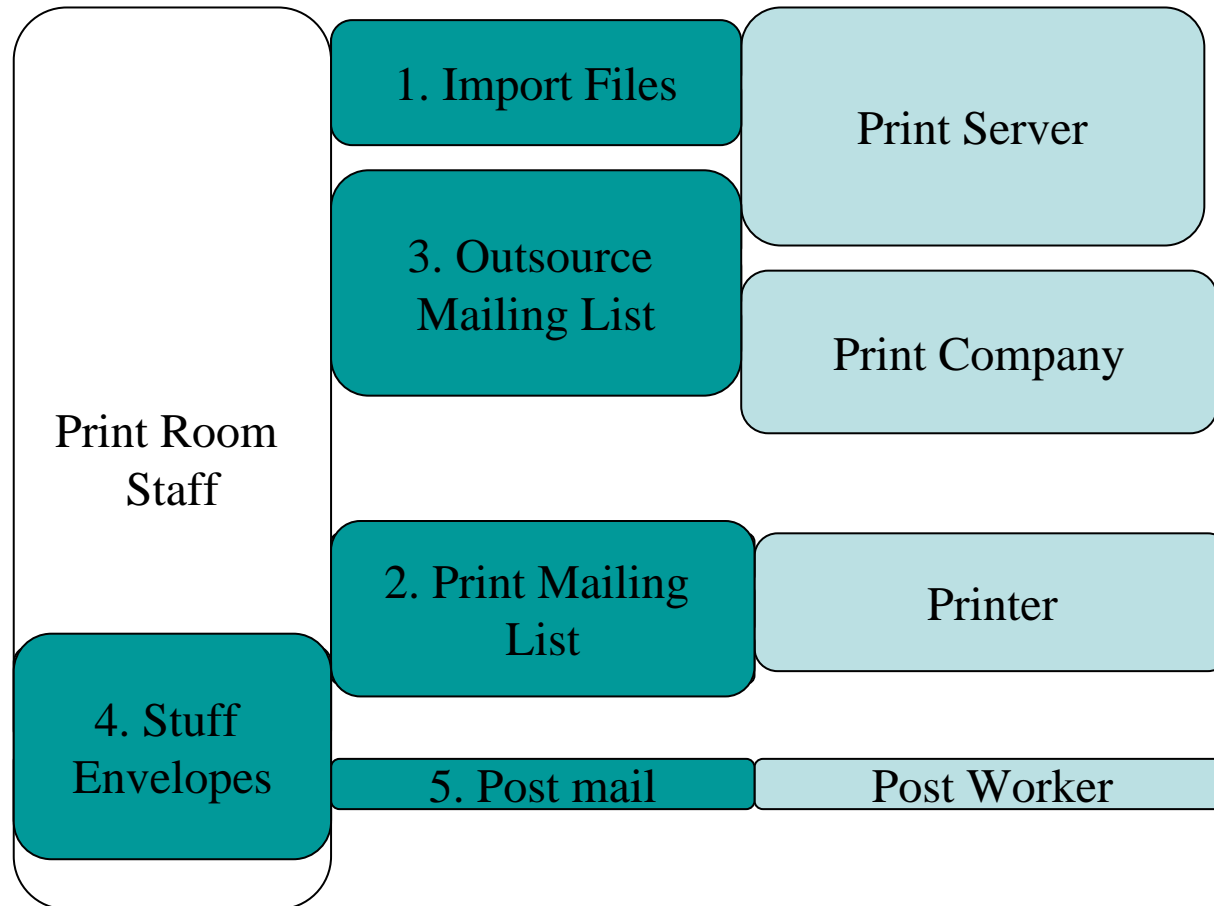

Matching Use Cases

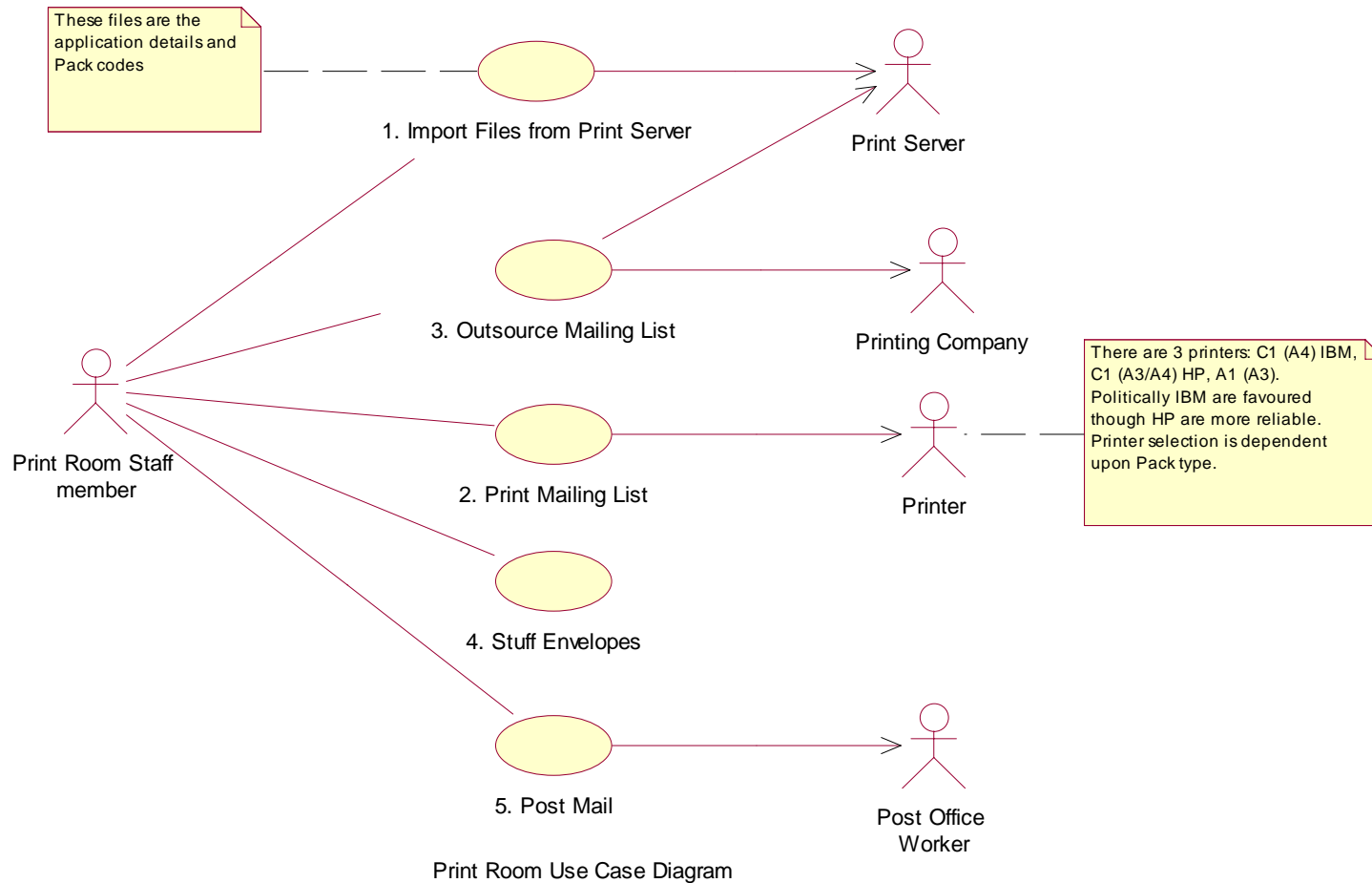

Rules (what have we done?)

- Overview of process components (POSD).
- Consider process model (RAD).
- Move towards use cases (procedural view?).
 - Maintain connections.
 - Demonstrated preservation of mapping.
- What rules / guidelines can be used to move from RAD to Use case diagram?
 - To make this more mechanistic
 - To move (straight) from RAD to Use Case.

RAD Connections: Literal

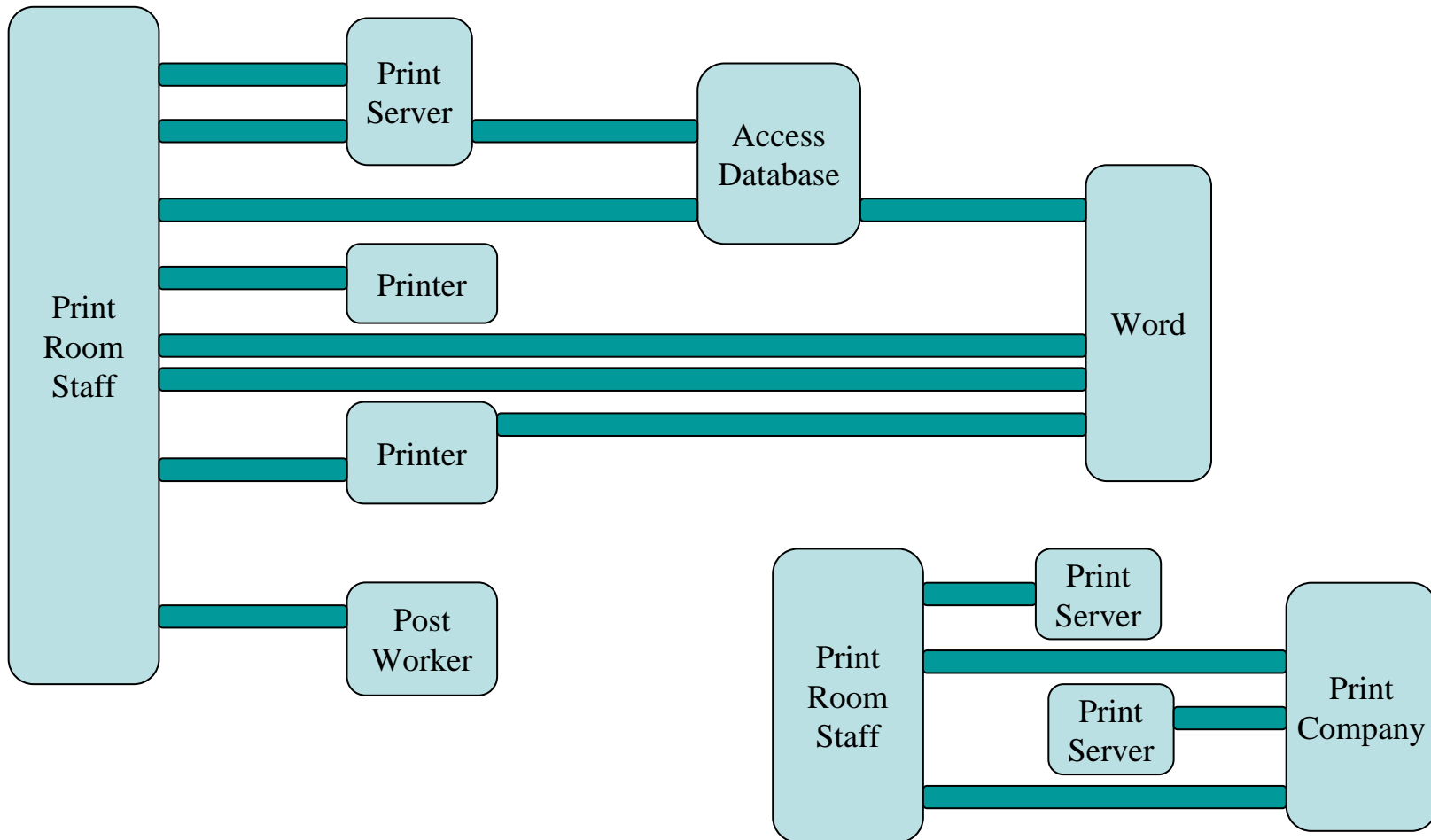

Connections: Bundled Again

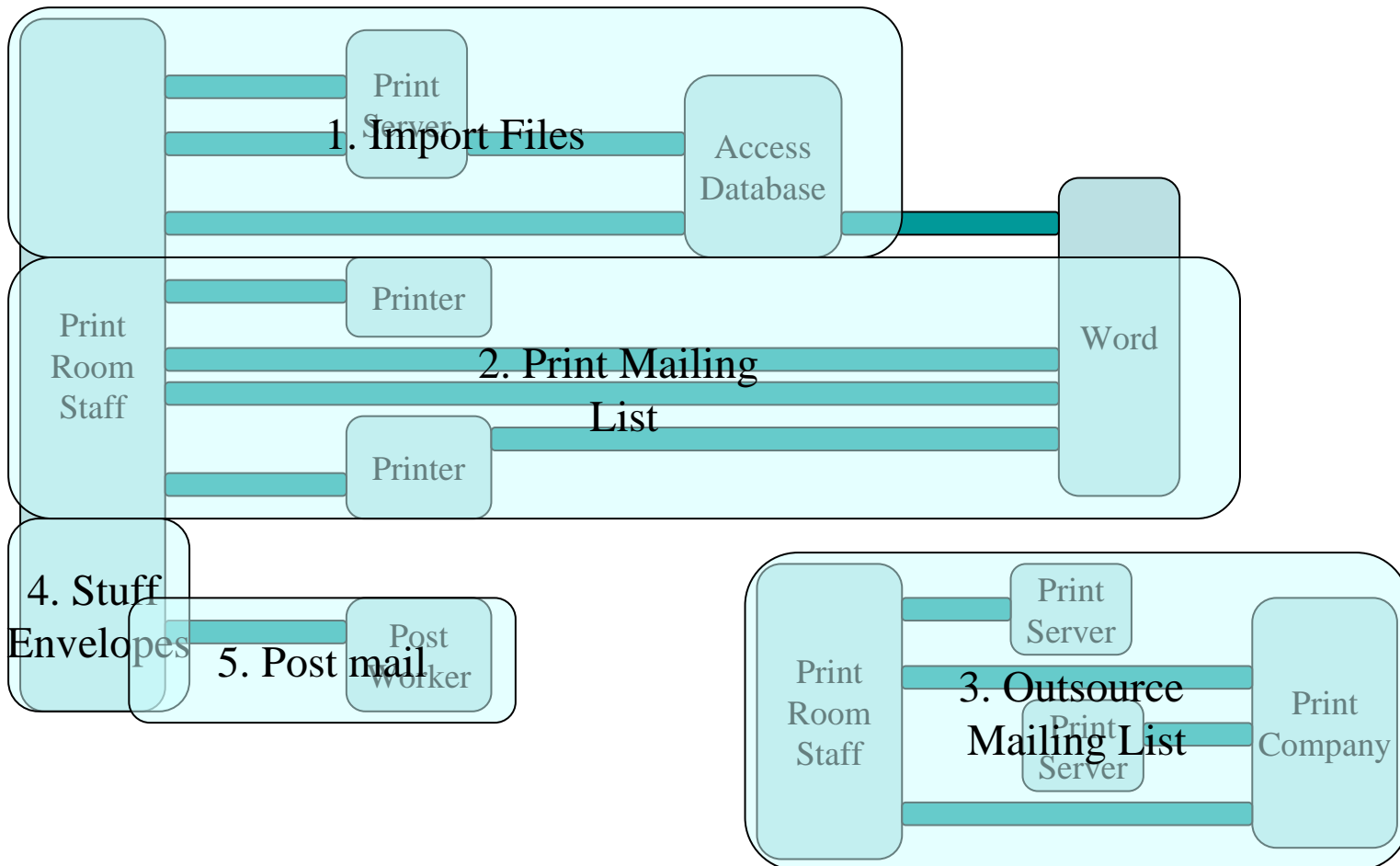

- RAD interaction detail not always helpful for moving towards Use Case.
 - Better to consider abstract connections (as POSD, or simplified RAD) and assign meaningful names.
 - POSD allows further scope for viewpoints.
 - Preservation of mapping helps to ensure that detail is not omitted.
- RAD phase helps ‘debug’ process.
 - Particularly where ‘enaction’ used.

Next Steps: Use Cases onwards

- Have moved from process description to use case diagram.
- Use cases help identify packages.
- Each Use cases has associated description.
- From descriptions we discover objects.
 - By asking sets of questions.
 - By refining descriptions.
 - By considering dependencies {further enaction}.

Envisioned Process RAD

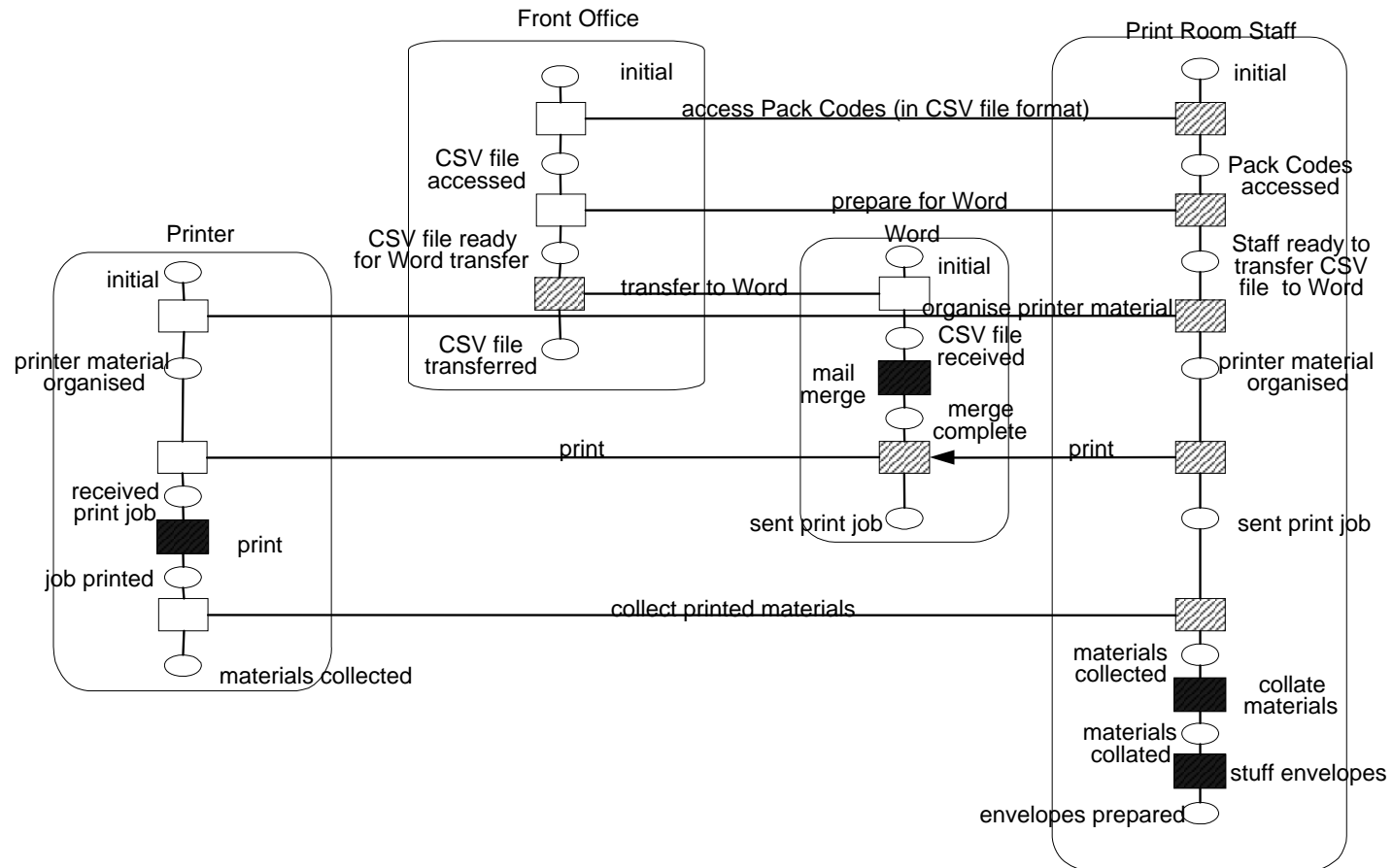

POSD Overview

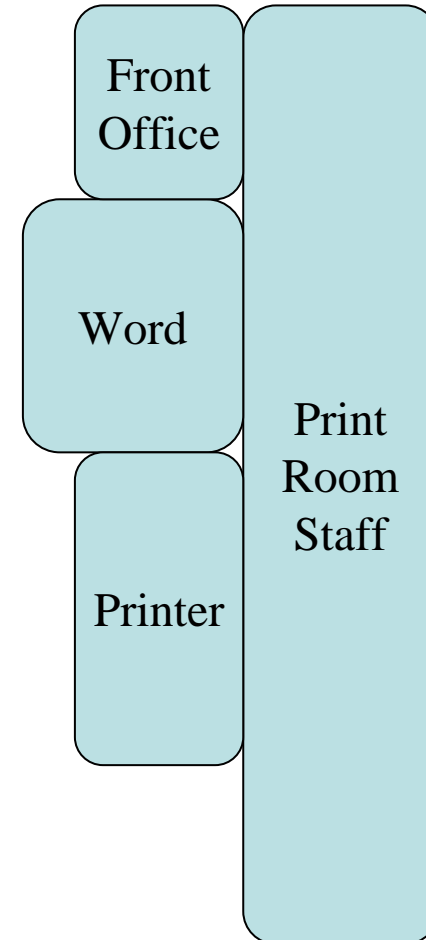
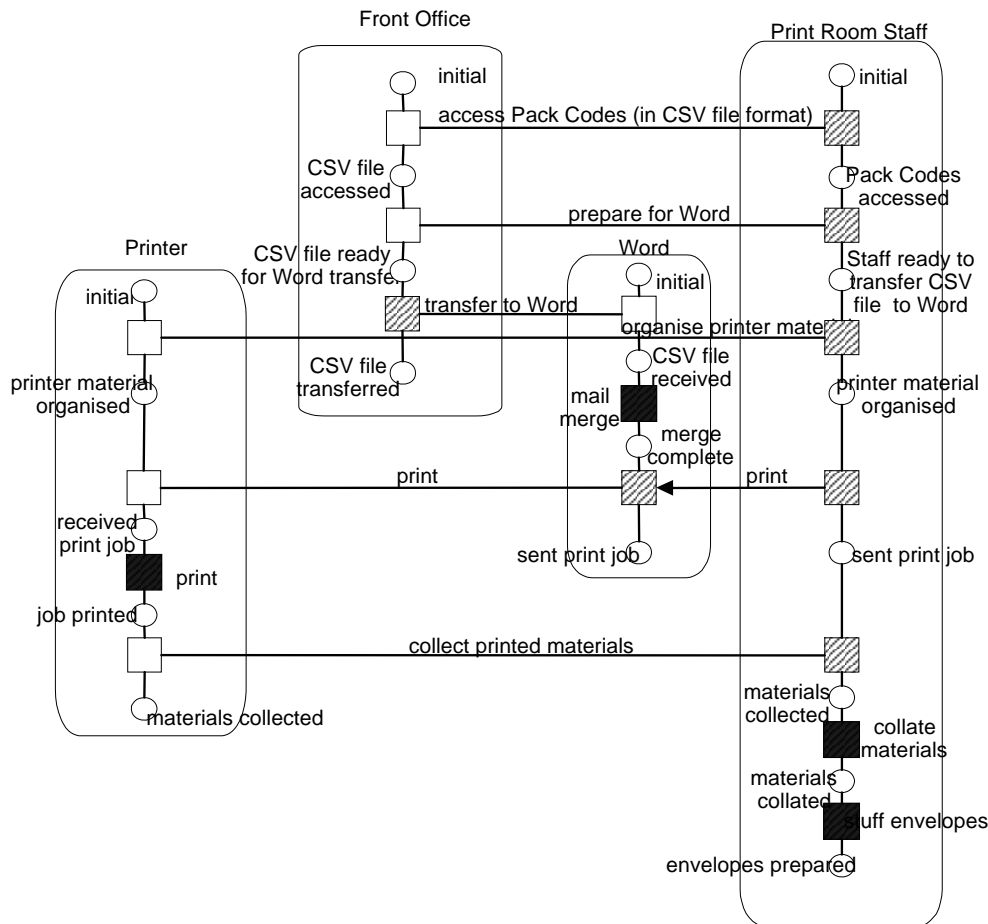

Overview with Connections

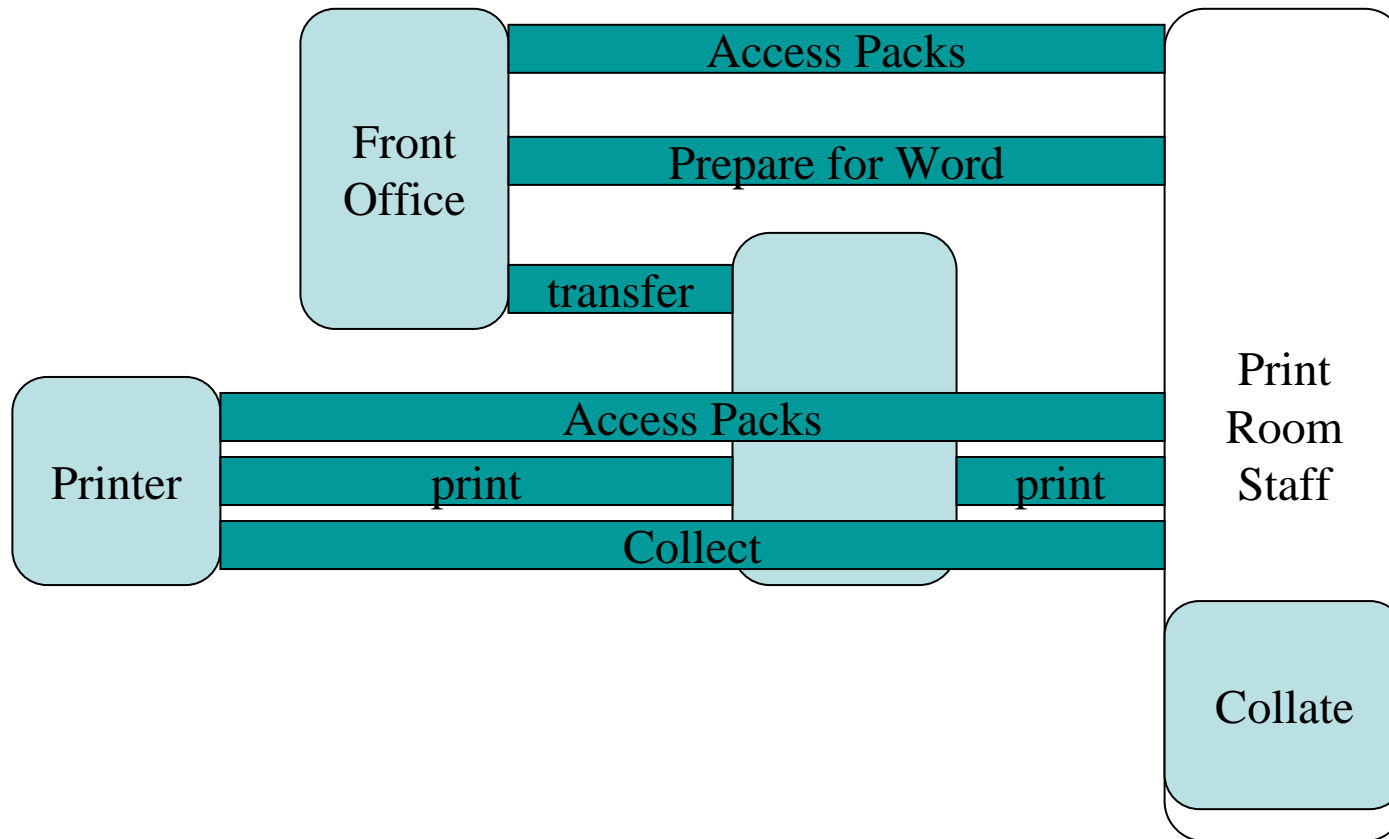

Connections Bundled

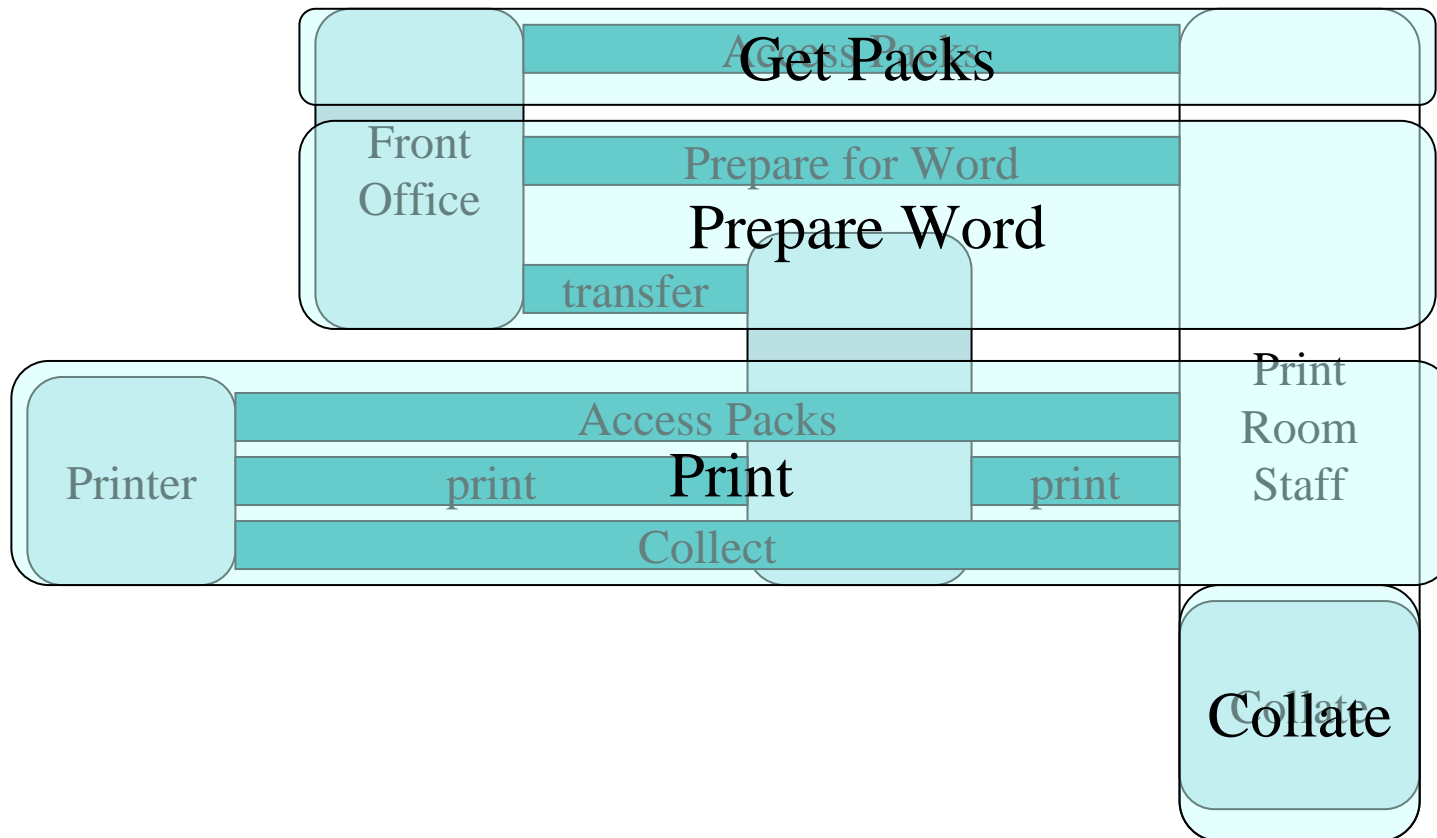

Matching Use Case

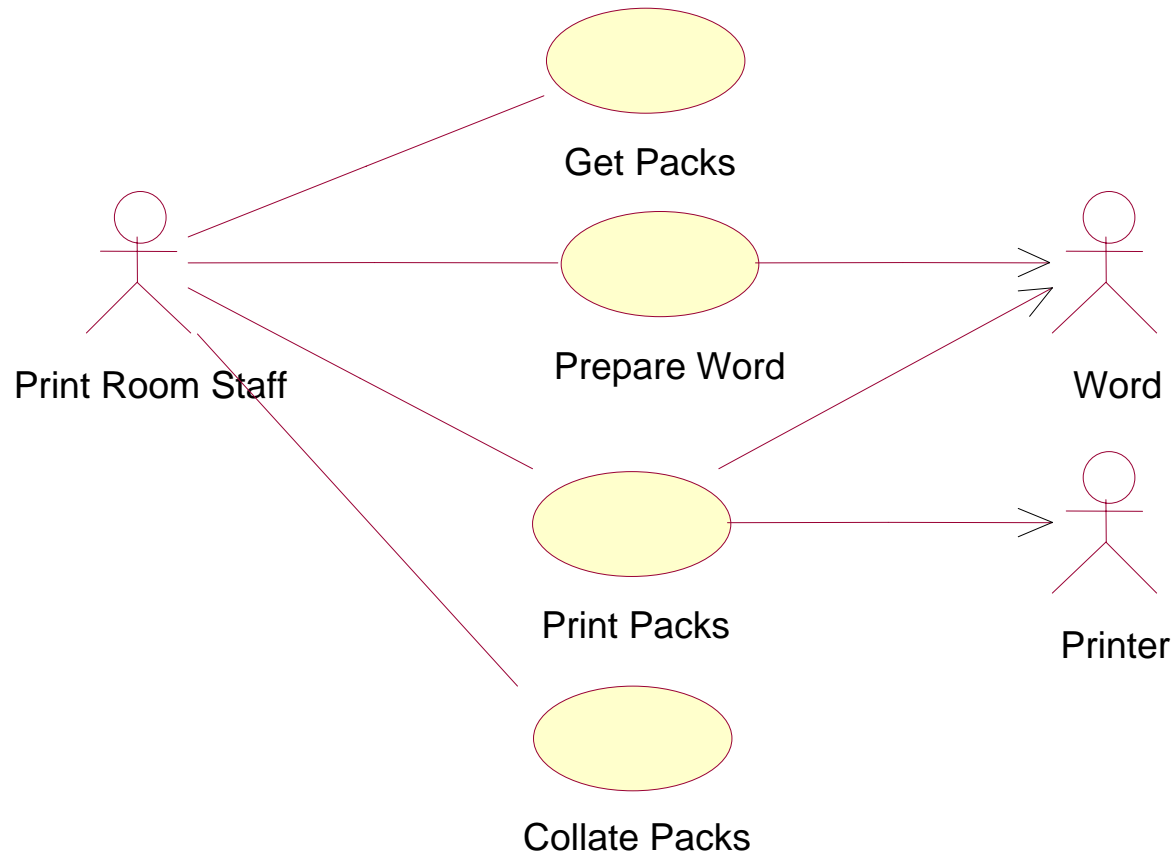

- Much activity within connections.
 - Some bundling of both interactions and actions into use cases.
- Move from Use Case of process to Use Case as specification.
 - Hence, some process elements not described
- Beware inconsistent levels of abstraction.
 - E.g., single interactions as Use Case
 - Multiple actions and interactions as a Use Case.