

### Mail Receiver

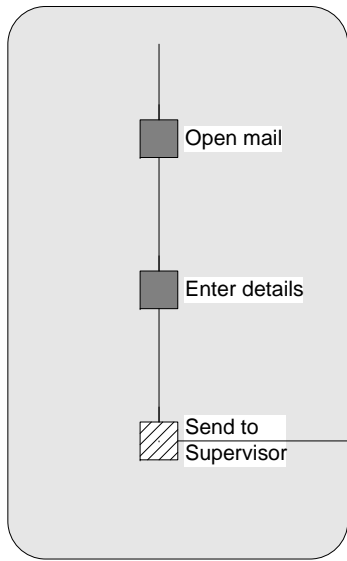

### Supervisor

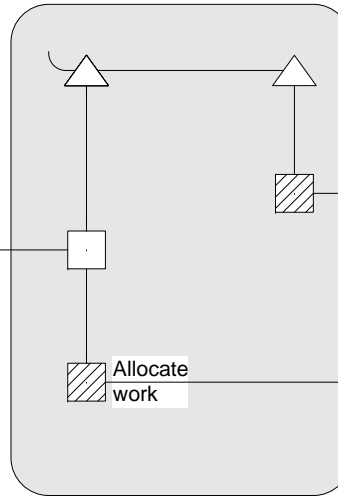

### Clerk

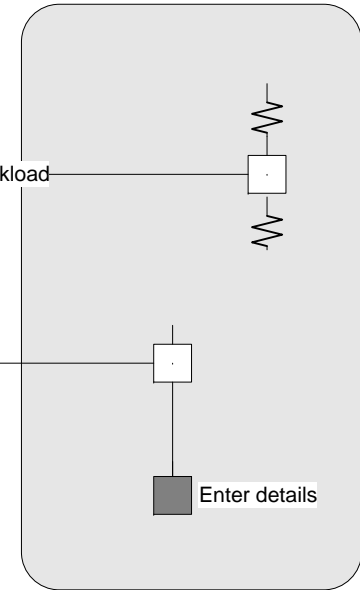

### Mail Sender

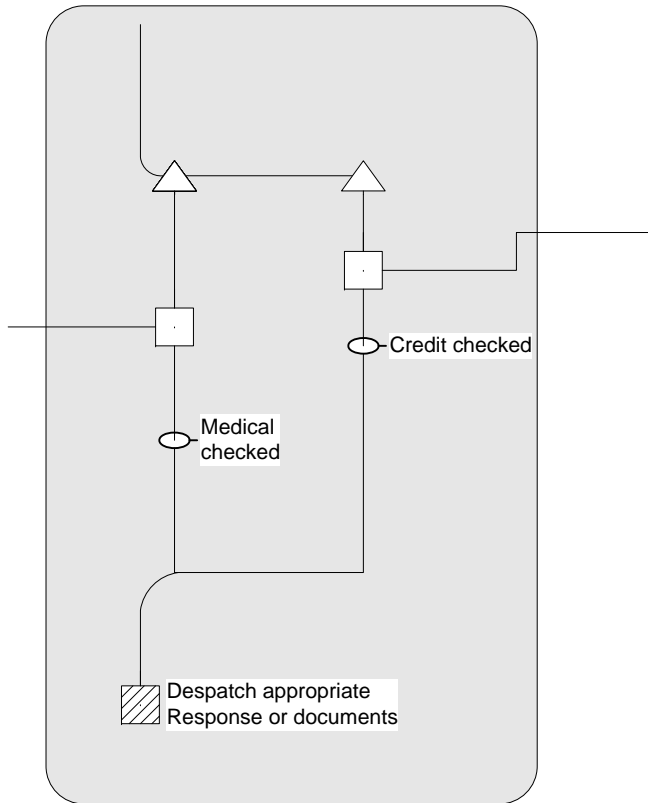

Check workload

Allocate work

Enter details

Despatch appropriate Response or documents