

Creating a best fit between Business Strategy and Web Services Capabilities using Problem Frames Modeling approach

Anju Jha¹, Karl Cox² & Keith Phalp³

**1 School of Computer Science and Engineering
University of New South Wales, anuj@cse.unsw.edu.au**

**2 Empirical Software Engineering,
National ICT Australia, Sydney, Australia, karl.cox@nicta.com.au**

**3 Software Systems Modelling Group
Bournemouth University, UK, kp@bmth.ac.uk**

Overview

Strategy and Web Services Capabilities using Problem Frames

- Rationale
- Proposed Method
- An example described
- Findings
- Conclusions
- Issues
- Further Work
- Relation to Wider Community

Problems and Solutions

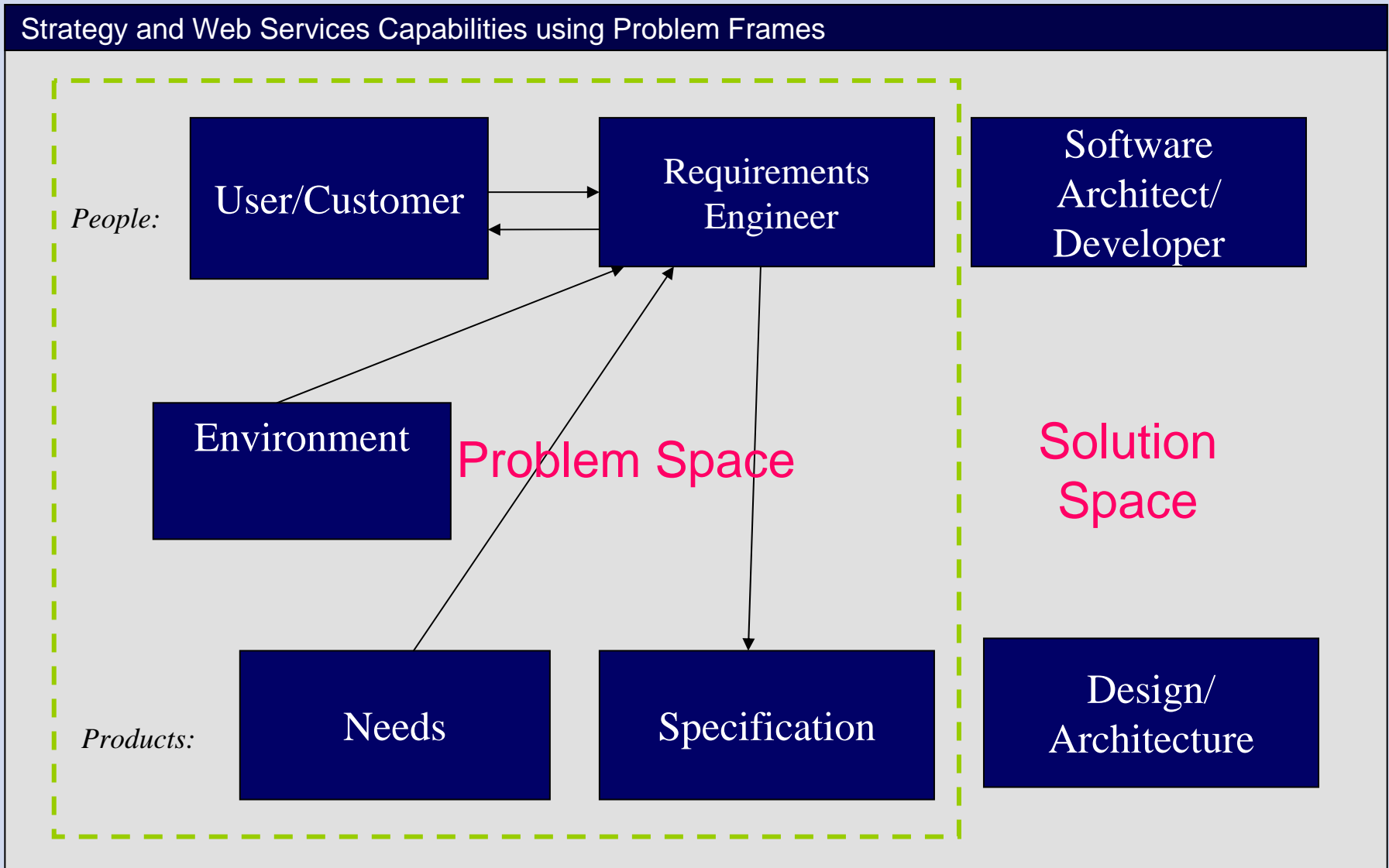

Rationale for Approach

Strategy and Web Services Capabilities using Problem Frames

- Significant growth in web services.
- RE for Web services concentrates on producing a specification, and perceives the specification as a guide for developers (less importance on validation).
- Little attention paid to describing the **real world problems** and the **business objectives** of an organisation deploying Web services.
- Realisation that web services (like other IT) should be aligned with business strategy, goals and objectives.
- Proposed (strategy oriented) method draws upon Balanced Scorecard and from and our previous work in aligning IT with Business Strategy (predominantly e-business domains).

Proposed Method

Strategy and Web Services Capabilities using Problem Frames

- Provides a roadmap from business strategy, to the strategic objectives in four dimensions:
 - Service innovation,
 - customer relationship management,
 - infrastructure management and financials,
 - to implementation.
- Uses **Progression of Problems** to understand the strategic objectives, business needs and business context of Web services from strategy to through to implementation.
- Uses **Problem frames** to describe the operational needs and the Web services context.

Research Questions

Strategy and Web Services Capabilities using Problem Frames

- RQ1: Is it possible to describe a business to IT problem in the context of requirements for Web services?
- RQ 2: Is it possible to describe the business context, business requirements and problem domain of an organisation adopting Web Services through appropriate requirements engineering framework?
- RQ2.1: Is it necessary to describe the business and problem context for Web services?
- Industrial experience suggests that a good grasp of the business context and domain context of Web services is needed before describing the specifications.
- So how can this be achieved?

RE Frameworks

Strategy and Web Services Capabilities using Problem Frames

Quick Definition of terms

- A **requirement** is a condition or capability needed by the user to solve a problem or achieve an **objective**.
- A Web service is a **capability** that an organization would deploy to meet its business objective.
- Several requirements engineering frameworks that could be used
- Not all are appropriate to describe the business context, business requirements and problem domain for Web services adequately.

Problem Frames

Strategy and Web Services Capabilities using Problem Frames

- Problem frames (Jackson) model the problem context.
- Also model the relationships amongst domains (or sub-domains), often using a specialised form of context diagram.
- A key benefit of the approach is the identification of five standard problem frames (or problem types), with differing model needs for requirements and specification.
- Five standard frames are: Control (Required behaviour and Commanded behaviour), Workpiece, Information (Continuous display or Requested reports), Transformation and Connection.
- One further simulation frame suggested by Bray.

Benefits of Problem Frames

Strategy and Web Services Capabilities using Problem Frames

- Describes the **real world** and how the intended software will change or guarantee real world conditions
- **Problem context** provides information about the structure, processes and tasks that are true of the problem domain.
- **Requirements** states which properties we wish to be true given a built software solution, the **machine** (later described in spec).

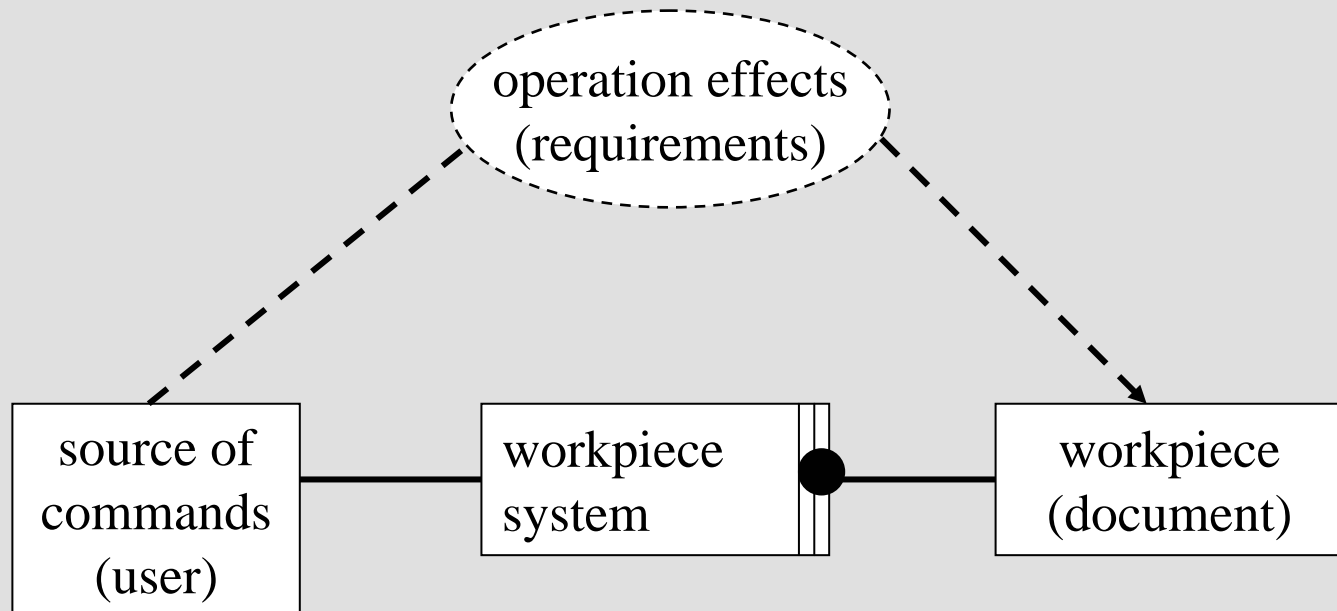

Progression of Problems

Strategy and Web Services Capabilities using Problem Frames

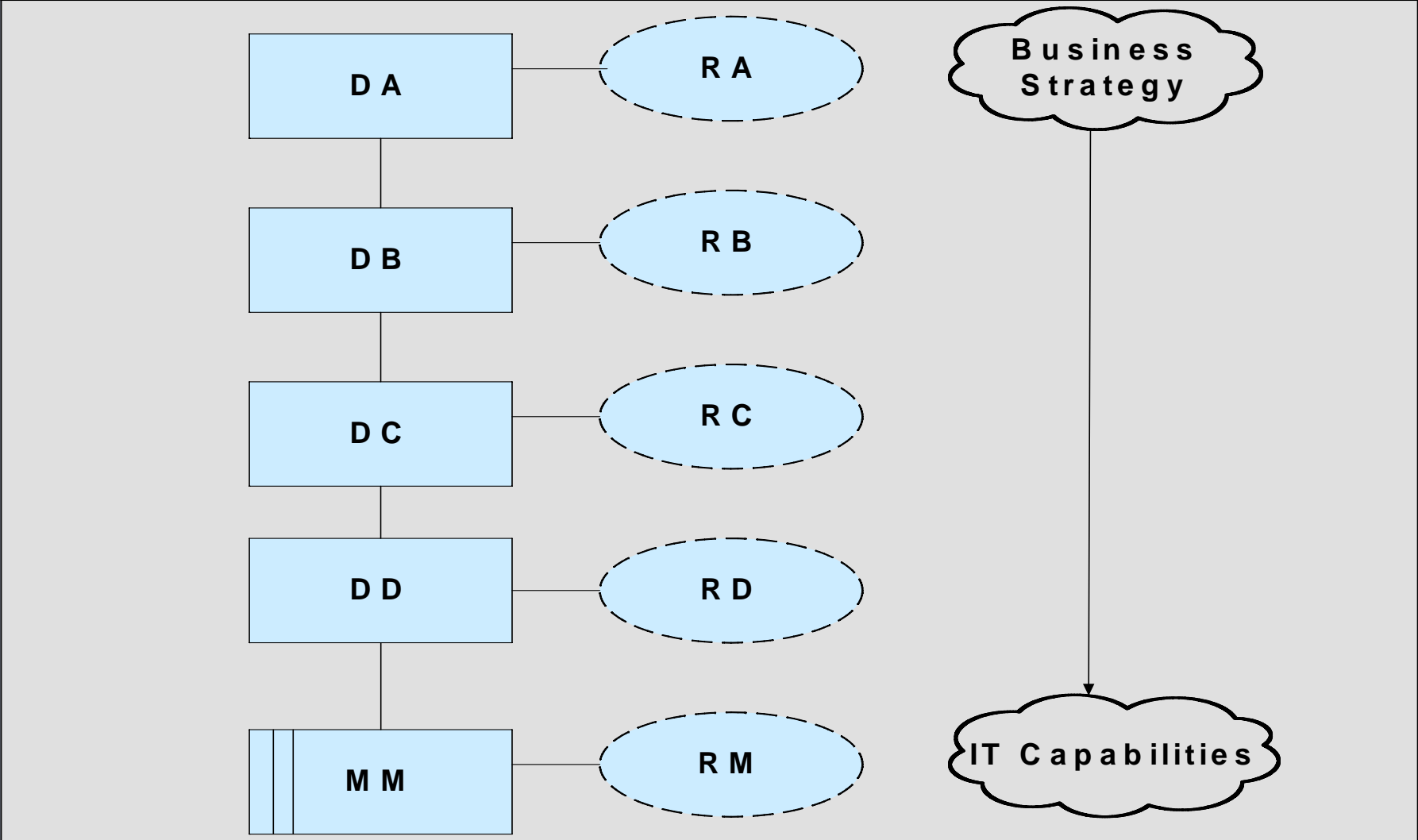

Method

Step 1: Understand Organizational Strategy/ Business Objective

Step 2: Use Progression of Problems to describe the Organization's business objective and business context from strategy to implementation

Step 3: Describe the Capabilities using problem frames

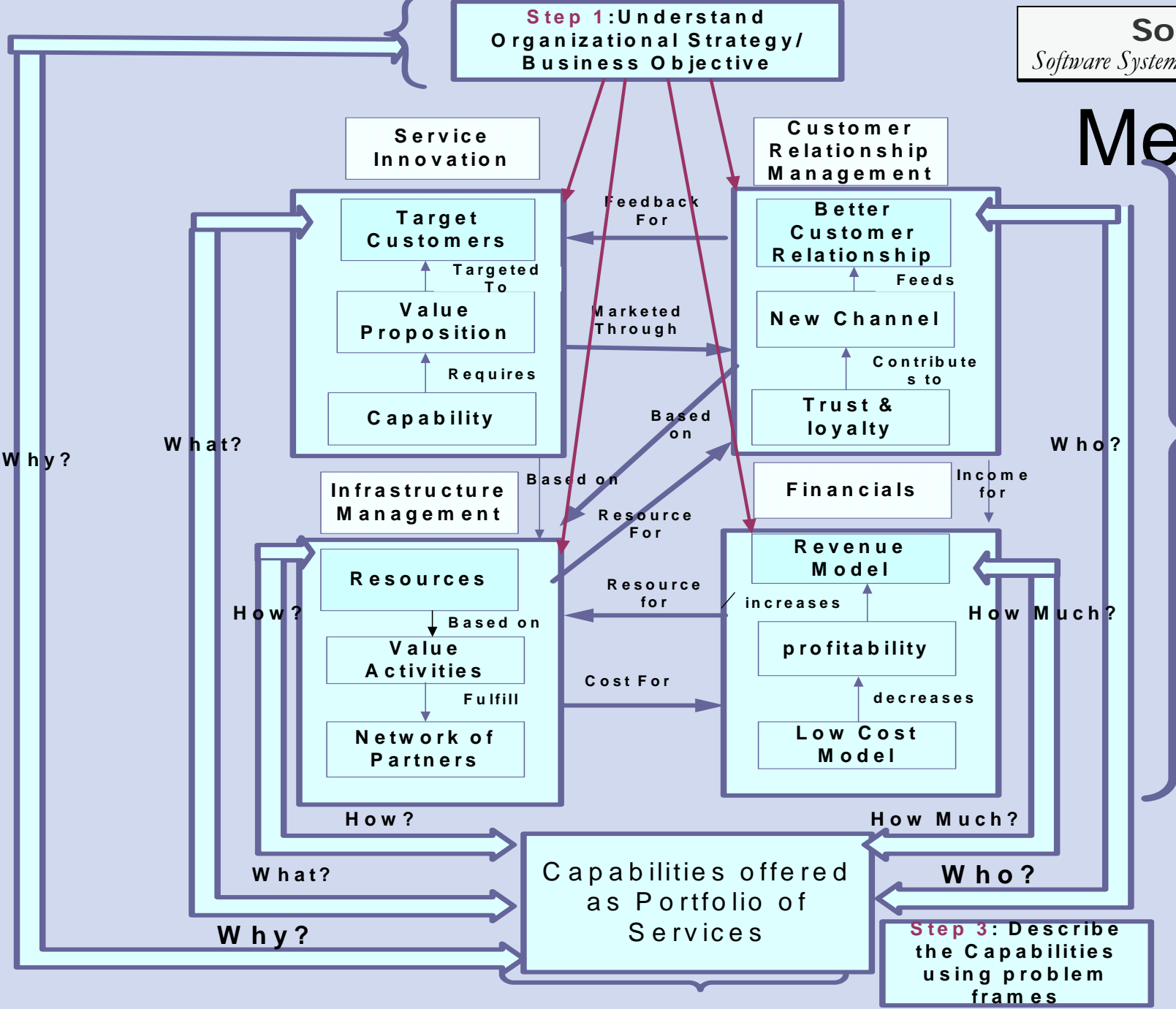

Steps in the Method: An Example - Amazon

Strategy and Web Services Capabilities using Problem Frames

- Amazon Web services is a business unit within Amazon.com that exposes the service capabilities to its business partners for a commission.
- Some of the Amazon's *WS capabilities offered to the associates are:*
- **Product details** and **pricing information** for virtually all products in the Amazon catalog.
- Extended Search: Associates can use Amazon's 'Advanced Search' functionality to search by multiple attributes like brand, price and category.
- Remote Shopping Cart: Amazon allows associates to add Amazon's Shopping Cart functionality to their own website.

STEP 1: Understand the Business Strategy

- Amazon's mission is to increase market share by exposing their products to end-customer.
- Amazon has created a Web API that allows associates (business partners) to incorporate Amazon's features into their website.

Dimensions	Strategic Objectives/Operational objectives	Context	Progression of Problems
1) Service Innovation	<p><u>Strategic Objectives:</u></p> <ol style="list-style-type: none"> 1) <i>Service Innovation</i> 2) Target innovative services to the <i>target customer</i>. 3) <i>Value proposition</i> to the customers 4) Value capabilities offered to the Associates. <p><u>Operational Objectives:</u></p> <p>Embed Web service capabilities into the Associate shop front</p>	<ol style="list-style-type: none"> 1) Amazon.com 2) Amazon Web services. 3) Associate 4) Web Services 5) Associate Shopfront 	POP (1)
2) Customer Relationship Management	<p><u>Strategic Objectives:</u></p> <ol style="list-style-type: none"> 1) <i>Improve Customer Relationship</i> 2) <i>New channels</i> are offered by Amazon web services. 3) <i>Trust and loyalty</i> between Partners 4) <i>New Business Opportunities</i> to the Associates. <p><u>Operational Objectives:</u></p> <p>Embed Web service capabilities into the Associate shop front</p>	<ol style="list-style-type: none"> 1) Amazon.com 2) Amazon Web services. 3) Associate 4) Web Services 5) Associate Shopfront 	POP (2)
3) Infrastructure Management	<p><u>Strategic Objectives:</u></p> <ol style="list-style-type: none"> 1) <i>Infrastructure Management</i> 2) <i>Resources</i> offered by Amazon Web services. 3) <i>Resources</i> made available to <i>Network of Partners</i>. 4) <i>Value activities</i> to make capabilities available <p><u>Operational Objectives:</u></p> <p>Embed Web service capabilities into the Associate shop front</p>	<ol style="list-style-type: none"> 1) Amazon.com 2) Amazon Web services. 3) Associate 4) Web Services 5) Associate Shopfront 	POP (3)
4) Financials	<p><u>Strategic Objectives:</u></p> <ol style="list-style-type: none"> 1) <i>Increase profitability</i> 2) Have a <i>Low cost Model</i> 3) <i>New revenue streams</i> to the associates. 4) <i>Low cost capabilities</i> offered to the customers <p><u>Operational Objectives:</u></p> <p>Embed Web service capabilities into the Associate shop front</p>	<ol style="list-style-type: none"> 1) Amazon.com 2) Amazon Web services. 3) Associate 4) Web Services 5) Associate Shopfront 	POP (4)

Step 2: Understand business objectives and business context

Strategy and Web Services Capabilities using Problem Frames

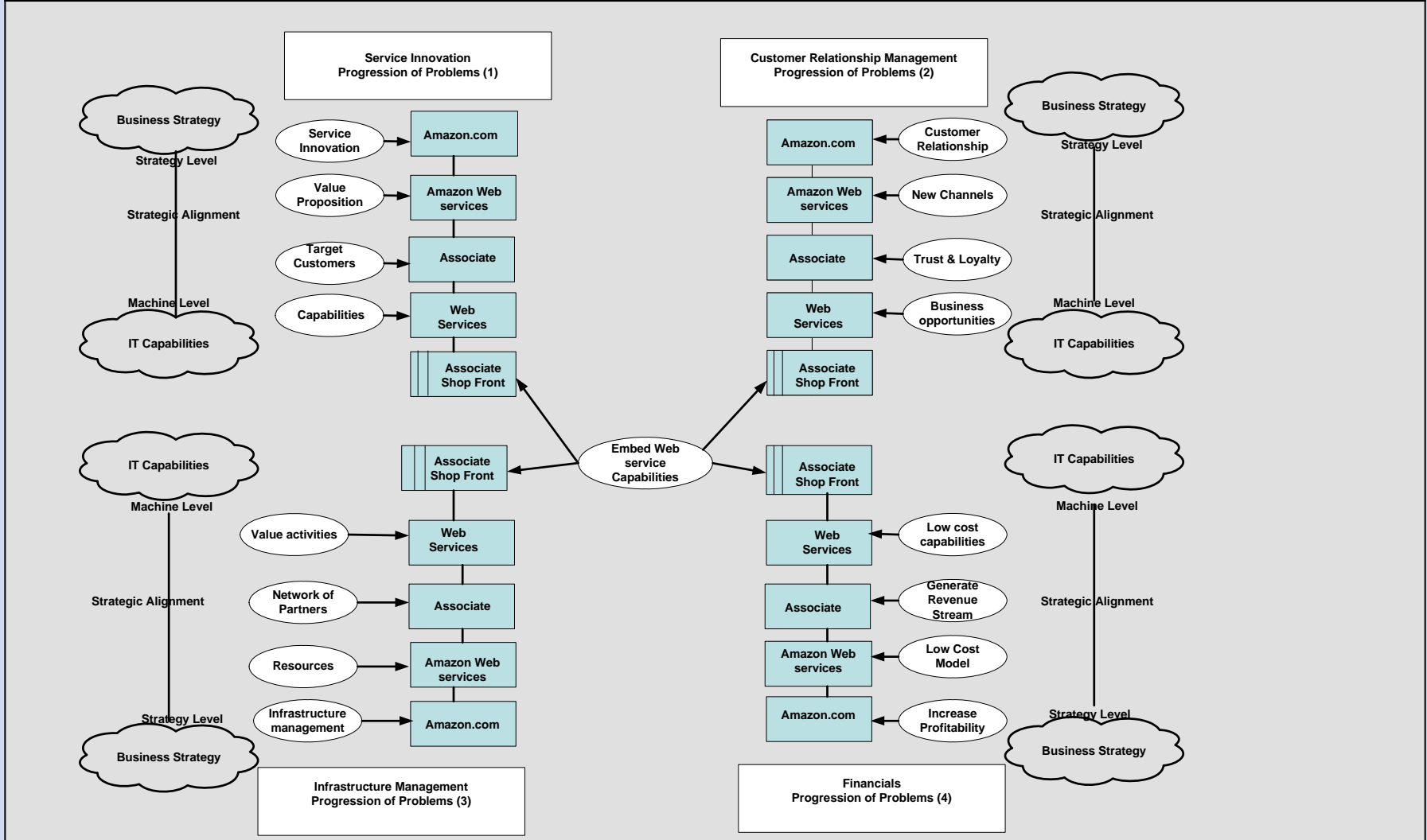

Step 3: Describe capabilities as of services using Problem Frames

Strategy and Web Services Capabilities using Problem Frames

- Once the associate accepts Amazon web service's value proposition it is all set to select appropriate capability at the 4th layer of Progressions diagram.
- **We use Problem frames to explicitly describe:**
- The business service capability provided.
- Application-to-Application interaction.
- The problem context and the domain in which the service operates.
- The outward description of the interfaces between the problem domain and the software that will integrate the interfaces.
- How the service consumer will use the capability.
- Amazon's capability using Problem frames.

Amazon - Associate

Strategy and Web Services Capabilities using Problem Frames

Shared Phenomena:

- a: AWS! {Identification_verification}
- b: AS! {Identification_details, data_request}
- c: AWS! {Data_sent};
- d: AS! {Data_received}
- e: AS! {Product_Data};
- f: PD(p)! {Product_Data}
- g: PD(r)! {Product_Data}
- h: ID! {Program_Code};
- i: P! {Output_Code}
- j: ID! {Program_Description}
- k: OD! {Screen_Output}

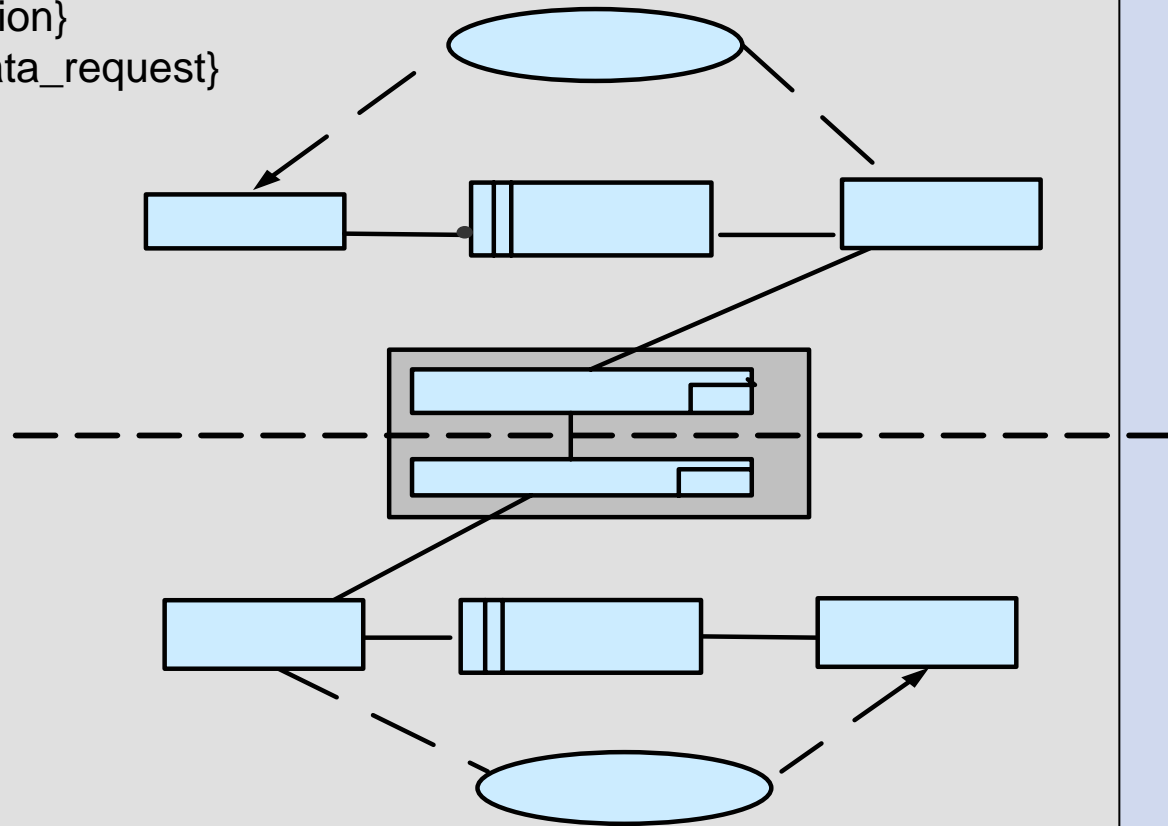

Conclusions

Strategy and Web Services Capabilities using Problem Frames

Which quality features are addressed by the paper?

Improve fit between the business strategy and the Web service capabilities
Aims to capture better the strategy/business objectives of an organization using Progression of Problems.

Guidance (roadmap) from business strategy, to the strategic objectives.

What is the main novelty/contribution of the paper?

Progression of Problem is used to describe the alignment.

Shows how Web Services context and requirements can be described as Problem Frames.

How will this novelty/contribution improve RE practice or RE research?

Realize the significance of aligning Web services initiative with the strategic objectives.

Emphasize the need to create alignment between the firms business strategy and the Web service capabilities.

Can the proposed approach be expected to scale to real-life problems?

Application on a live project is the next step in testing the idea's scalability.

Issues and Further Work

Strategy and Web Services Capabilities using Problem Frames

