



**Bournemouth
University**

Recap & Outline

- Have reviewed what we mean by analysis, requirements, specification and external design (ARSED).
- Recognition that current (use case, UML) and past methods are not ideal for capturing requirements.
- Suggested process models as a way to inform requirements.
- Given glimpse of work to come: RADs, moving to spec etc.
- Have informally introduced RADs and tried an example.
- This week – formal introduction to Role models and RADs (and arguments for their suitability).
- Alternatives
- Discussion of seminar example.



Bournemouth
University

Role Models: Rationale

- A quick overview of the flavours of process model, where they came from, and place in the software process.
- Strategic and business models
- Desirable model features (or requirements for our model).
- Role Models – Arguments for these kinds of models.
- Role Activity Diagrams
- Most arguments for RADs contrast with procedural, object based etc. However, in reality there are other alternatives too – e.g., UML variants and OMG process modelling language – BPMN.

Place in Process: OMG OO Lifecycle

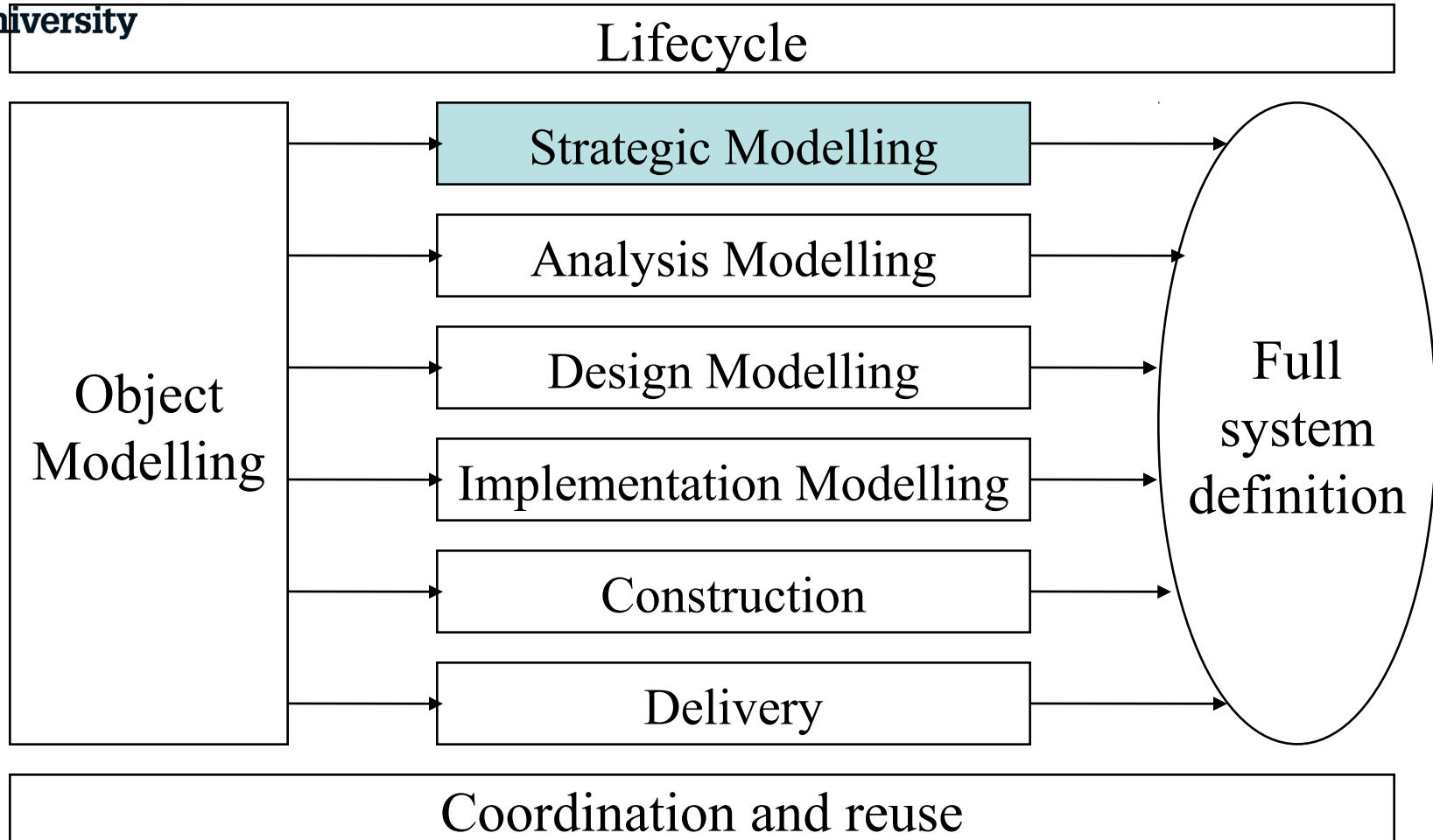

Flavours of Process Modelling

- Models of the Software Development Process.
 - Key ideas: Process programming, process maturity, study of people, tools, measurement, notations.
- Models of Client (business) processes.
 - Business process modelling.
 - Strategic modelling, requirements and analysis.
 - Alignment of IT with strategy and operation.
- Software development as a business process.
- Historically goals for process modelling could be related to levels of desired automation (IPSEs).
- This has re-emerged with the move towards model driven toolsets (MDA and particularly the CIM phase).
- Again the idea is to provide software tools – but now to have accessible process modelling approaches so that we can involve the stakeholders within the clients.

Modelling: Experience

- Start with an easy to understand approach (diagrams).
- Even simple diagrammatic notations lead to complex models
 - Which users find difficult to comprehend.
 - Mechanisms to add structure to detailed models can help.
- Enactable notations do help - but users need to be shielded from them.
- NOTE - Latterly we find the same experiences from those who are attempting to involve stakeholders within the CIM phases of model driven development.
- That is - we NEED accessible models
- We need to CONSIDER the model audience.

Layers and Validation

Elicitation / Validation

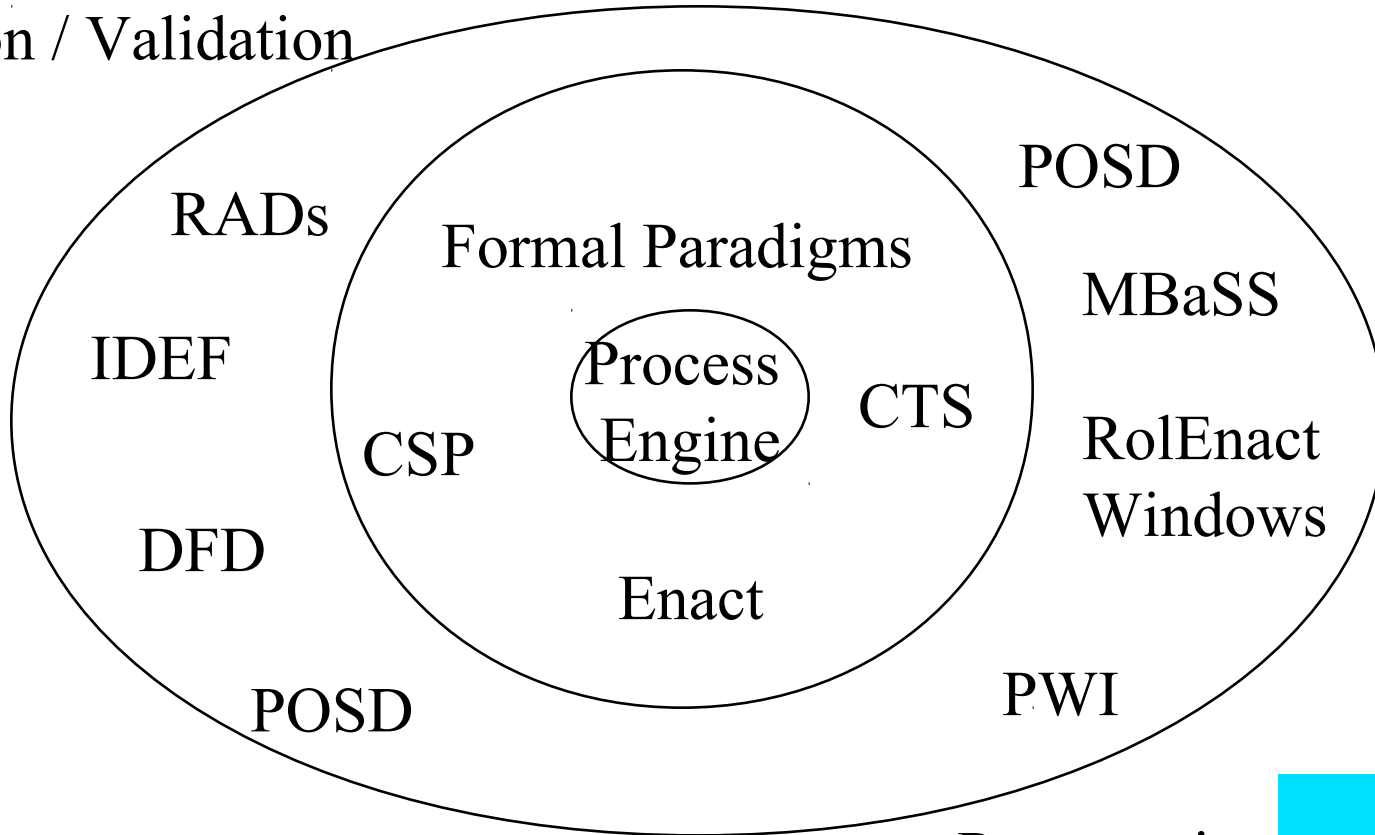

Presentation
Enaction /





Bournemouth
University

Choosing Notations

- Mostly concerned with Process Capture (as opposed to Analysis and Presentation phases of modelling – see Phalp 1998 – IST).
 - However, the notation should allow us to discuss, validate, and experiment with process changes. (Hence, capability to present to users, and to carry out some qualitative, or possibly even quantitative, analysis).
- What makes a good model?
- By this we mean what notations or modelling approaches.
- Later on (time allowing) we will also consider how we judge the quality of our model.
- What are our constraints – as IT people?

Desirable Model Features

- Primitives correspond to features found in the *real-world*.
- Models *essential* properties.
- Intuitive & appropriate.
- Accessible by all model users. (Audience).
- Sound underlying *semantics*.
- Model can handle complexity.

Real World? Features

- Goals - Those things the organisation / business is trying to achieve.
- Business rules - Limits (constraints) the business places on people.
 - Legacy: constraints of existing working (not under consideration for change).
- What people *do* (their actions) to achieve goals.
- How people *interact* (work collaboratively).
- *Of course, as with objects, similarity to the 'real world' is a dangerous argument.*

Manifest themselves in:

- Responsibilities.
- Delegation of tasks and authority.
- *Ordering of activities, pre conditions, pre-actions and post conditions.*
- Criteria for decisions.
- Reporting on progress and giving approval.

Typical actions

- produce
- distribute
- find
- check
- send
- receive
- identify
- create
- wait
- monitor
- choose
- write
- organise
- plan

Typical interactions

- agree
- approve
- delegate work (task)
- pass (information, work).
- give authority for
- report on status
- wait (for something)

Interactions are
points of
synchronisation.

Don't need?

- Activities where people act completely on their own.
- Mechanisms to support the process (e.g., to support interaction we use e-mail).
- Non-essential data.

- *Of course all modelling is abstraction.*
- *The trick is to decide what to throw away.*

Pragmatic – Well for IT Development Constraints

- Need to consider mapping to Spec and Design, specifically to UML models.
 - A use case or class description.
 - Aid identification of some business objects.
- Need to use terms acceptable to the business audience.
- Need to have fairly rigorous semantics.

What do process actors need to know?

‘For an individual (or group) in the organisation to carry out their activities, they need to know what activities they must take part in, in what order those activities must take place, what other individuals or groups they must interact with, and which actions are dependent upon those interactions’.

Handy, C. (1976), ‘Understanding Organisations’, Penguin.



**Bournemouth
University**

Role Based Models

- ‘Role based models satisfy these requirements by grouping activities into ‘roles’, which describe the desired behaviour of individual groups, or systems’.

Ould, M.A. (1992), An introduction to Process Modelling using RADs, in IOPTCLUB Practical Process Modelling, Mountbatten Hotel, Monmouth Street, Covent Garden, London.

- ‘A role involves a set of activities which, taken together, carry out a particular responsibility or set of responsibilities’.

Ould, M.A. (1995), Business Processes modelling and Analysis for Re-engineering and Improvement, John Wiley & Sons.

Procedural Models

- Other top contender for process description is a procedural model. But:
- Difficult to abstract away from the detail (mechanism) of current process. This inhibits change.
- Models tend to have a decomposition related to function, hence activities which are to be carried out by individuals are often spread around the model.

Other contenders – 1) UML

- Have debated with colleagues and students over some years.
- UML sequence diagrams can give insight of sequence and messages (interaction) across objects.
- Activity diagrams can provide a useful state view.
- RADs provide both of these perspectives in one diagram, and, crucially match a business (role) view of the world
- Many (even internal) converts

- Statecharts can be quite powerful.
- Use cases appear to be accessible – though semantics?
- However, clearly UML gives a consistent mapping (or should do).

Other contenders – 2) BPMN

- BPMN is the OMG preferred Business Process Modelling Notation
- BPMN also maps to BPEL (the execution language).
- BPMN has a very UML (or is that OMG) like view of the world, and consistent notational constructs.
- *(VIDE undertook a review of possible BPM approaches).*
- However, many notational elements.
- Have used in practice and with users. Have also used variants developed by research partners, and have worked on using a subset to describe processes (and move to mashups).
- I would argue that it is not intuitive for what would be my target audience (often not IT professionals).
- STORY – One process modelling tools company.

Other contenders – 3)BRADs

- It could be argued that in seeking an accessible notation we might want even less formal approaches.
- Our VIDE project (though without RADs) looked at using what were termed pre-CIM notations (and even had a prior 'scrapbook' phase with 'bloops').
- We used a Bloops, Roles, Activities, Data, model, which could then be transformed to more formal models. Indeed, we moved from scrapbook, to BRADs, to VCLL (a variant of BPMN) and then transformation to Class diagrams etc.
- There were also alternative routes.
- However, CIM – PIM – PSM, does tend to overlook the whole system boundary, requirements vs spec issue.
- Another area where we are contributing is formal incorporation of a requirements phase within CIM, and on the concept (really a deliberately antagonistic argument rather than belief) of pre-CIM.

Role Activity Diagrams

- Original paper Ould & Roberts (1986).
- Formal semantics. Similar to Petri Nets. Can be mapped to other formal notations.
- Widely used. Promoted by Praxis (Ould, Huckvale & others) & Coordination Systems (Roberts).
- Applied to a number of domains, e.g., Software Engineering, finance, Retail and Construction.
- Noted recent books (last week's lecture).
- Started out for IT usage (IPSE), taken on by BPM, and in recent years (ironically) been found again by software engineering and requirements.

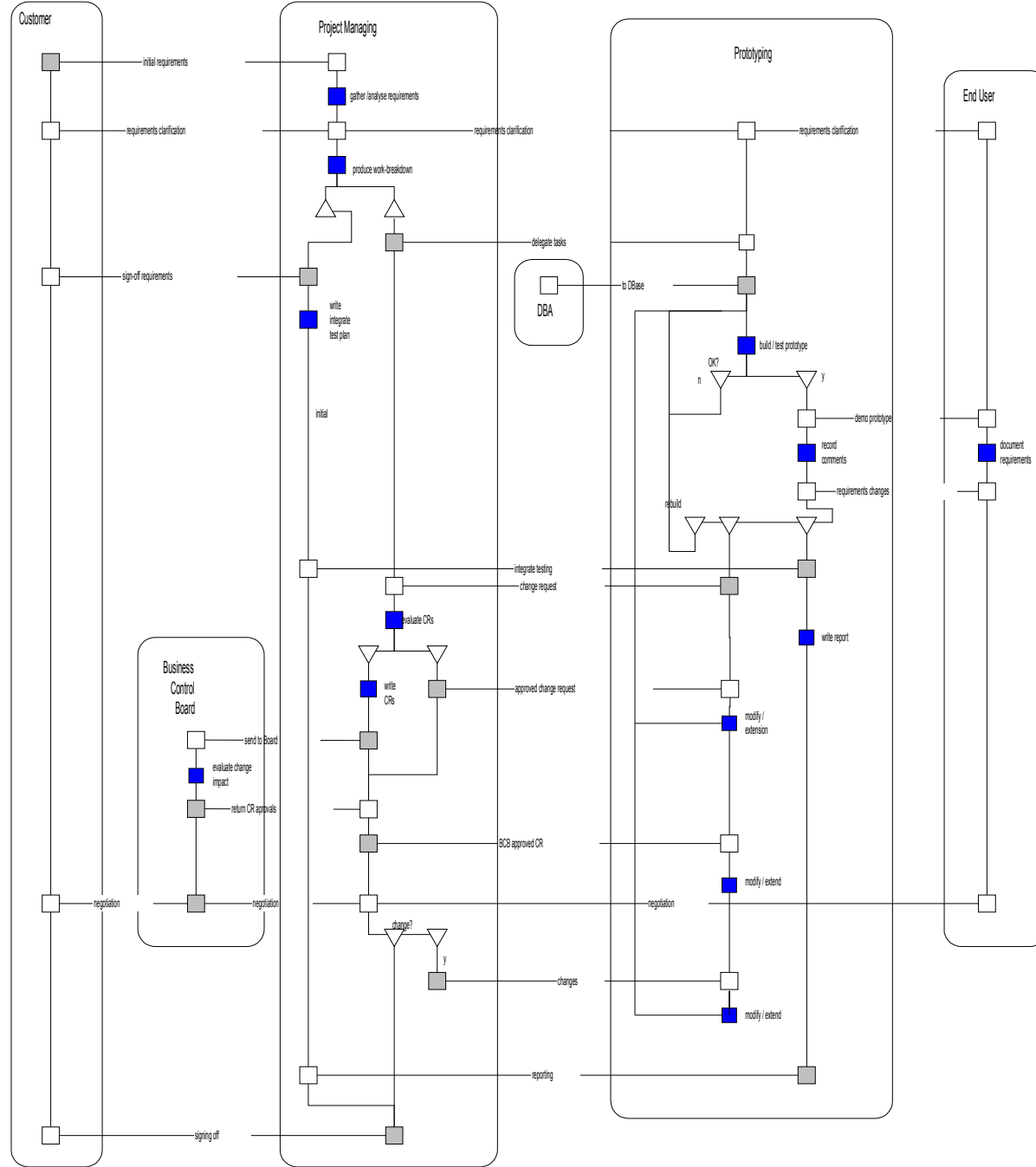

Roles and RADs

- Business depicted in terms of roles.
- Roles are types - e.g., they describe the behaviour of a class of individuals.
- A Role is independent of other roles, but communicates through interactions.
- Instances of roles therefore act in parallel, with the interaction between roles being their only synchronisation mechanism.

An Example: New projects

- An external event signifies approval for a new project. As a result the 'Divisional Director' is able to start a new project.
- This is followed by the creation of a new 'Project Manager'. Now the Project Manager and Divisional Director are able to agree a Terms of Reference (TOR) for the project.
- The Project Manager is now able to start a new 'Designer'. The Project Manager must also write a TOR and then agree this TOR with the Designer.

Example Continued

- The Designer must ‘prepare an estimate’ and agree the estimate with the Project Manager.
 - (Since this takes place only after the Designer has prepared the estimate the Designer drives the interaction).
- Only then can the Project Manager go ahead and ‘prepare a plan’.
- On completion of the plan the Project Manager gives the plan to the Designer.

Further details

- The Designer is ready to design when they have the plan and have chosen the method.
- Having produced a design, the Designer must 'carry out a design quality check'.
- If the design is not OK, then the designer must go back to design.
- Once the design is acceptable its is given to the Project Manager.
- Finally the Project Manger produces a project debrief report.

Adding States

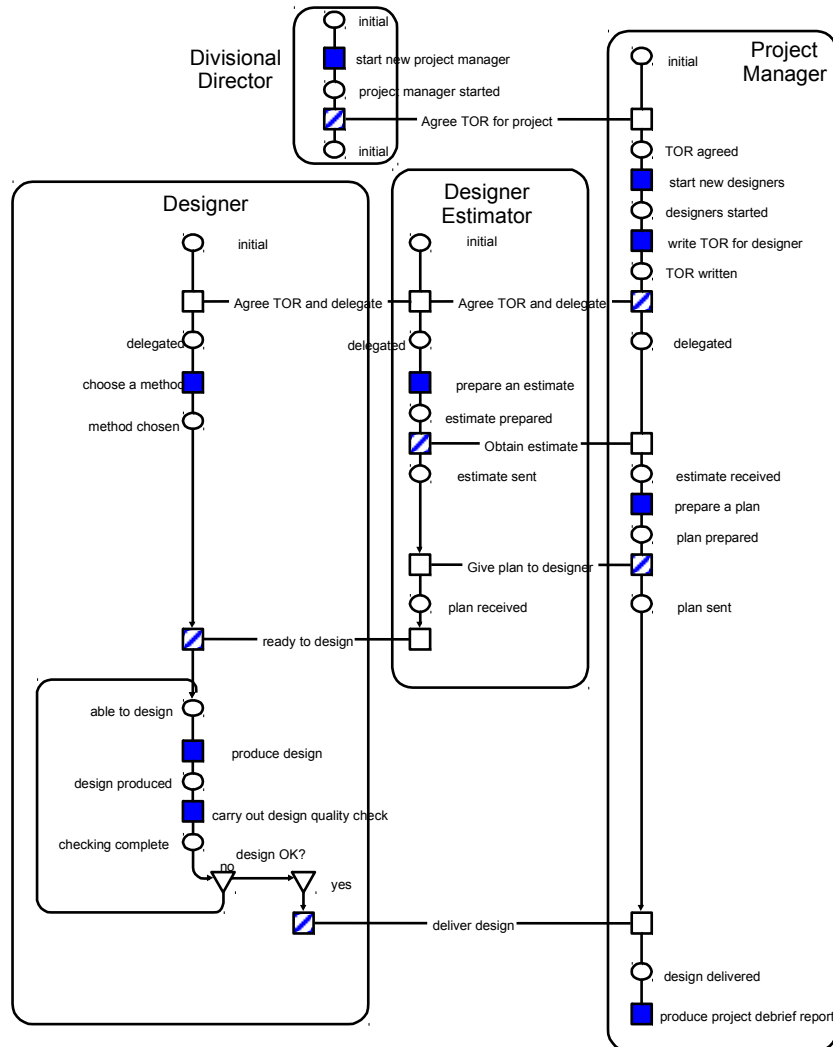

RAD Components

- Roles are:
 - The ‘Designer’, The ‘Project Manager’ and the ‘Divisional Director’.
- What are some of the actions?
- What are some of the interactions?
- Are there any choices?
- Are there any parallel or concurrent threads?

Actions

- An action is an activity which the role carries out in isolation.
- Carrying out an action moves the role from its present state to the next state.

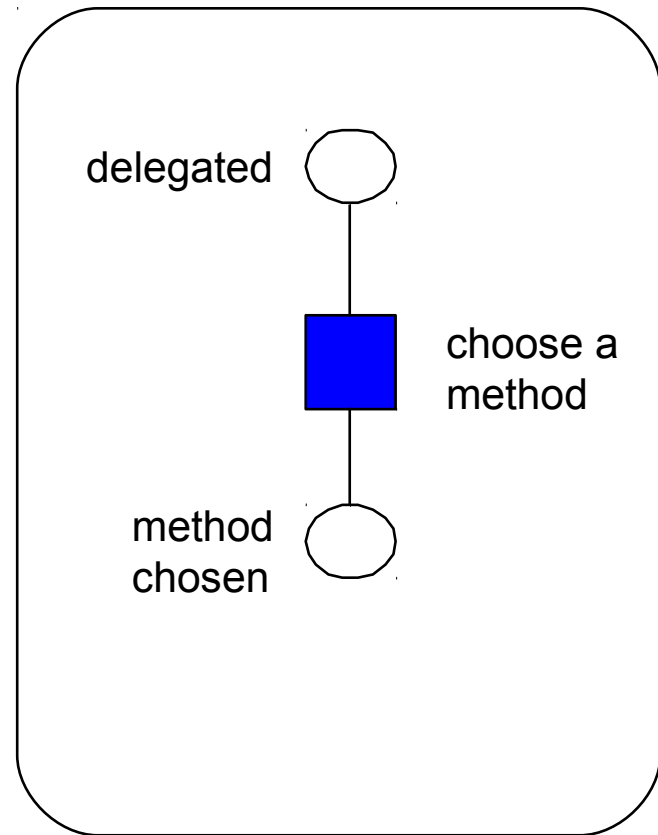

Interactions

- An activity carried out at the same point as another activity (or other activities) in another role (or roles). A shared event.
- The consequence of an interaction is that all of the roles involved move from their current state to their next state.
- Interaction must be initiated by some (driving) role.
- Interactions are synchronous.

Synchronous Interactions

- Are interactions in the real world synchronous?
- Are interactions in the real asynchronous?
 - Conceptually some are, though many hidden interactions. Also depends on perspective.
 - As an example (email).
- If interactions are often asynchronous, then why would we have a synchronous model?
- How can we use synchronous models to model both sorts of interactions?

Types of Interaction

- Demonstration of synchronous and asynchronous interactions.
- We used a buffer.
- In process modelling, one often finds many people who seem to act as buffers!

Iteration

- Iteration is where a state may be revisited. Shown by:
 - Drawing a loop back to a previous point on the role.
 - Having the post-state of an action as a previously named state.
- Typically used when there is some checking or control mechanism to be modelled.

- Thread of control in a role need not proceed sequentially.
- Choice or case-refinement. There may be any number of alternative threads but only one of the threads (or cases) may be chosen.
- Concurrent threads or part-refinement. Each thread represents part of the path. The threads all join together again after the split denoting that all paths have been completed.

Using State Information

- Not required to explicitly label the states of a role, though some authors prefer to do so.
- Labelling states (with circles or ellipses) helps the semantics of the role become clearer.
 - Labels make explicit the pre-conditions, pre-actions and consequences (post-conditions) of each activity.
 - Sometimes need to separate parallel threads into separate (or main and sub) roles..
- Diagram becomes larger and this may hamper understanding.

Constructing RADs

- Given a description of a business process.
- Produce a Role Activity Diagram.
 - List roles, actions & interactions.
 - Decide where there are part and case refinements.
 - List any assumptions you have made.
 - Try to describe the essential business process, and not the current implementation detail.
- The Example follows:

Constructing RADs

- **Taken from Martin Ould's IOPT Presentation of RADs**
- *A day where I "saw the light", and stopped trying to model everything with DFDs.*
- **The Process Scenario**
- The main steps from receipt of proposal to dispatch of policy papers.
- In the Mail Room the Mail Room Clerk opens incoming mail and enters basic details into the computer, such as customer name, agency reference number, type of business.
- The system automatically allocates a reference number and creates a work-item record for the application. The work-item is automatically routed to one of several Supervisors, depending on the agency reference number.
- A supervisor allocates a work-item to one of their Clerks. They can also allocate the work to themselves if all of their clerks are busy.
- The Supervisor may check the workload of the clerk at any time.
- The Clerk enters details from the application (address, age, health-checks,...).
- The Clerk continues processing an application. They check a database to see if there has been any previous business with the Customer. If not, a credit check is requested from an external agency. When the reply is received, the Clerk accepts or rejects the application. The Clerk may also ask the system to remind them when a reply is overdue.
- The underwriter also assesses the application, either working from a different site or from home. They decide whether a medical examination is needed, and if so, send a letter requesting one. The Underwriter may also ask the system to remind them when a reply is overdue.
- If both the Clerk and the Underwriter accept the application, the Mail Room Clerk dispatches policy documents to the Customer. Otherwise, a rejection is sent.

Role Activity Diagrams

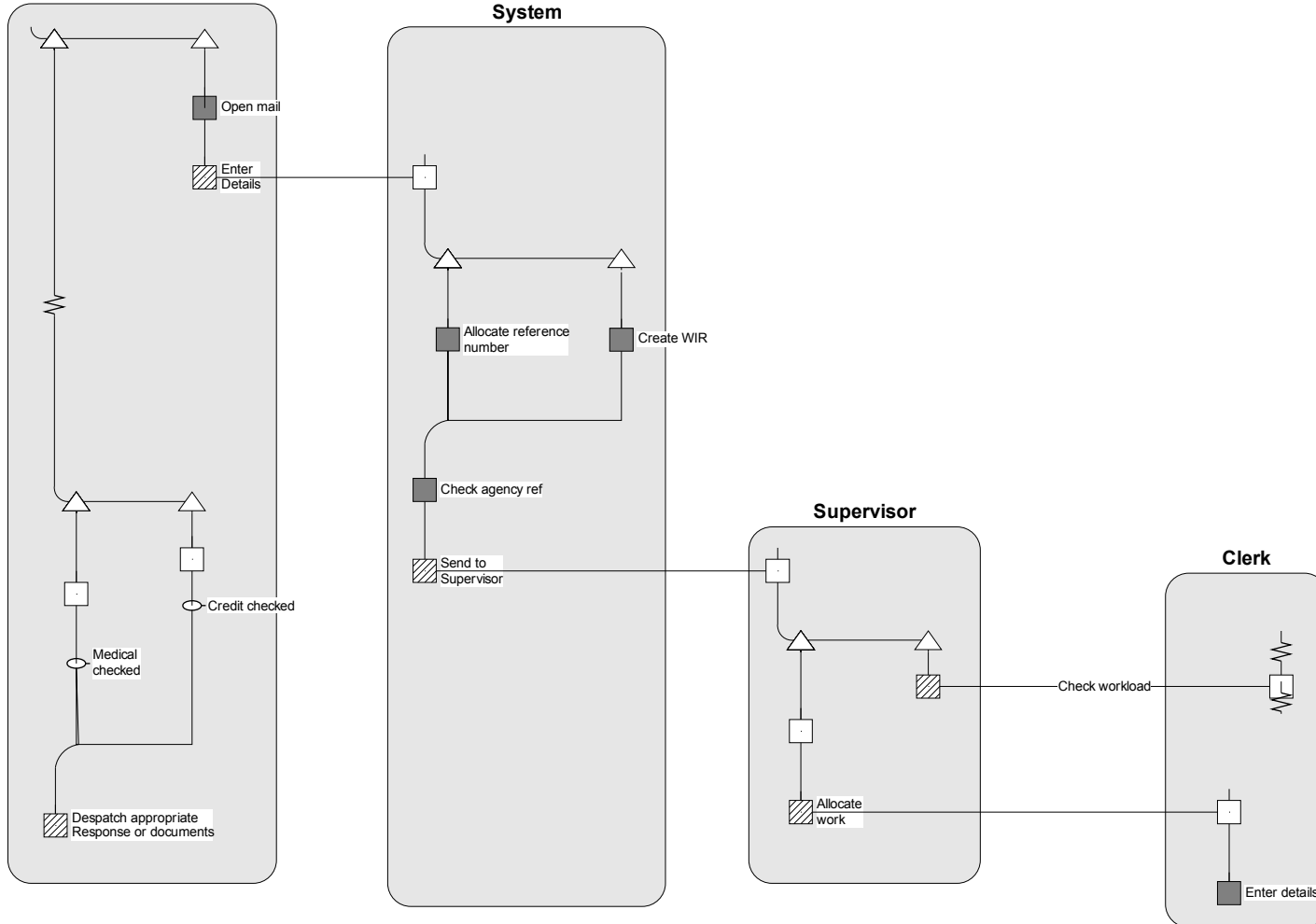

Summary

- Process modelling can be used to inform requirements
- Role based models are a useful approach for many scenarios.
- Introduced Role Activity Diagrams
- Simple Exercises
- Still to consider how process models can fit with other RE aspects (in the document).

Describing RADs

- Given a RAD of a business process.
- Produce a textual description.
 - Note roles, actions & interactions.
 - Consider whether states act as pre or post conditions. Describe this too.
 - List any problems or errors within the RAD .
 - List any assumptions you have made.
- *I know: It's the reverse of what you expect.*

